

# OWNER'S MANUAL

## MANLEY SLAM!

Stereo Limiter And Micpre



**MANLEY LABORATORIES, INC.  
13880 MAGNOLIA AVE.  
CHINO, CA. 91710  
TEL: (909) 627-4256  
FAX: (909) 628-2482**

**<http://www.manleylabs.com>  
EveAnna's email: [emanley @ manleylabs.com](mailto:emanley@manleylabs.com)  
Tech Support: [service @ manleylabs.com](mailto:service@manleylabs.com)**

**REV. 11-22-2004**

## CONTENTS

<i>SECTION</i>	<i>PAGE</i>
INTRODUCTION	3, 4
POWER SUPPLY	5
BACK PANEL & CONNECTING	6, 7, 8, 9
FRONT PANEL	10, 11
METERING	12, 13, 14
LIMITERS, HINTS, ETC.	15, 16, 17, 18
DIGITAL RAMBLINGS	19
THE GUTS, INSTALLING THE A/D/A, ALIGNMENTS	21, 22, 23, 24,25
TROUBLESHOOTING	26, 27
MAINS CONNECTIONS	28
SPECIFICATIONS	29,30
ADDENDUM FOR SLAM! MASTERING	32,34
WARRANTY	35
WARRANTY REGISTRATION	36
APPENDIX 1 - EXAMPLE SETTINGS	37
APPENDIX 1 - TEMPLATE FOR STORING SETTINGS	38,39

## INTRODUCTION

### **THANK YOU!...**

for choosing the Manley **SLAM!**. This unit combines Mic and Instrument Preamps, 4 limiters, comprehensive metering and is ready for or already has the digital converter option. As one might expect, the basic operations are fairly simple and instructions may not be needed - but - the **SLAM!** has a lot of advanced features, and we strongly recommend reading through the manual. There are a lot of tricks and features that are not so obvious.

In truth, the **SLAM!** started with the idea of an updated Electro-Optical Limiter and the original working name was ELOP II. That didn't last long. First we developed a fast FET limiter, decided that fast LED metering was appropriate, then added a mic pre, decided that this box would make the ideal "analog insert in a digital world", then added almost every request and suggestion the customers had given us over the years. And somewhere during all this, decided each little part had to be right, and much was going to be quite new and elaborate. In the end, ELOP II was not at all descriptive and after a 'name this box' contest on our website it became the **SLAM!**.

We can start right at the basic tube circuits. These designs are unlike any others we know of, including previous Manley circuits, so this is not a box with an old mic pre combined with an old Opto Limiter and a borrowed FET limiter with a conventional digital converter tossed in the salad. This is all new. The tube circuit is a hybrid FET/tube design first used in the Manley Steelhead phono preamp and provides the advantages of both technologies. You get the low noise of FETs, the headroom of tubes, the gain of both and lower distortion than either typically, and a new texture in your tool kit.

This is the beginning of the story and continues through the product and the manual. Some manuals seem to imply that if you use 'this box' then you are an instant mastering engineer or top producer with all the tools they use. This strange manual is filled with warnings, caution flags, grumblings about some aspects of digital and has extended quotations from other other manufacturers. Our intention is to help the user, supply a bit of under-reported info, and give equal time to both what might help provide the sound you've been looking for and what might be considered questionable or dangerous to your music. The **SLAM!**, like other powerful processors, can be great or horrible depending on how it is used or abused and if something here helps avoid disasters, then we have happy customers.

### **GENERAL NOTES**

#### **LOCATION & VENTILATION**

The Manley **SLAM!** must be installed in a stable location with ample ventilation. It is recommended, if this unit is rack mounted, that you allow enough clearance on the top of the unit such that a constant flow of air can move through the ventilation holes. Airflow is primarily through the bottom panel vents and out through the top.

You should also not mount the **SLAM!** where there is likely to be strong magnetic fields such as directly over or under power amplifiers or large power consuming devices. The other gear's fuse values tend to give a hint of whether it draws major power and is likely to create a bigger magnetic field. Magnetic fields might cause a hum in the **SLAM!** and occasionally you may need to experiment with placement in the rack to eliminate the hum. In most situations it should be quiet and trouble free.

We also suggest that you get familiar with the back panel switches and jacks before it gets mounted in a rack. If you have the digital option, experiment with the filter settings, dither, etc to find your favorite settings, then rack it.

#### **WATER & MOISTURE**

As with any electrical equipment, this equipment should not be used near water or moisture. Beer is OK though.

#### **SERVICING**

The user should not attempt to service this unit beyond that described in the owner's manual.

Refer all servicing to your dealer or Manley Laboratories. The factory technicians are available for questions by phone (909) 627-4256 or by email at <service@manleylabs.com>. Fill in your warranty card! Check the manual - Your question is probably anticipated and answered within these pages..... RTFM

## The Swiss Army Knife

The SLAM! is an unusual product that doesn't quite fit into a simple category. We get questions like "Why have a mic-pre on a limiter?", "Why have a DAC on a mic-pre?" and "Why so many input and output jacks?" and "Why no hard-wire bypass on this mastering processor?". And the only answer is "It's not just a ....., it does a lot more". It isn't a channel strip - no EQ, besides being stereo. It isn't just another front-end for the workstation. It isn't just a mastering processor. Maybe the SLAM! is a new category.

The SLAM! is intended to be the reference analog I/O (input/output) for a digital studio - the first choice analog insert for digital with strengths as an input device, output device and killer go-louder box. Sometimes digital gets cold and sterile, and people reach for tube processors for particular vintage colors, the 'warmth factor', the ballz, the thing that plug-ins or digital processors are not quite doing for 'em. So the SLAM! has an outrageous D/A and A/D option which sets it up as 'THE' Insert, and can be used with any other analog (or digital) gear to process tracks already on hard disk and then return them as pristine or mangled as desired. This requires great converters and analog circuits that can be super clean or dirty or in-between. The DAC can be pristine high-end solid state, tube, or driven hard for a wide range of colors. The ADC uses a transformer (iron) for its front end (and no chips) and is intended to be a 'warm' converter, because most everybody has the other kind.

The SLAM! is an outboard limiter and a new low-noise high gain tube mic-pre, and a mastering processor, and a DI, and possibly the best converter in your rack. As a mic pre it offers about 70 dB of gain and a new circuit, unlike any previous Manley PreAmp. The gain stages are based on a circuit developed by Mitch Margolis for the SteelHead phono pre-amp. Mitch also designed the VIPRE. The SLAM! can be used as a mastering processor (not a multi-band limiter), a processor that real mastering engineers use to create loudness without messing up the mix. As a DI or Instrument Input it offers 2 impedances 100K and 10 meg ohms, plenty of gain, limiting, and if you want to have fun use both channels with your fave EQ inserted between, and use the optional A/D straight into the workstation.

Swiss army knife is the most appropriate description. A multi-purpose, well constructed, generally useful tool. The analog to digital converters also have the Swiss connection. They are designed and built by a Swiss company called Anagram Technologies who are not well known in pro-audio but getting an enviable reputation in the high-end audiophile market. Stereophile Magazine in April 2002 (p77&79) named them the 'kings of digital filters' and they build converters for Audio Aero, Camelot Technologies, Nagra, and Manley.

What makes Anagram's converters so special? The DACs up-sample to 192K and in the process remove jitter almost completely and to the point where A/D/A worst case jitter components are well below the -144 dB measurement limit of 24 bit digital. The analog to digital converter similarly has a permanent sample rate of 192K and then down-samples to any of the common data rates like 48K. This provides both the audible benefits of 192K and the practical benefits of a 48K data rate, like relaxed requirements for giga-bits of storage space. This is all done with proprietary software running on a pair of very fast SHARC DSP chips and 40 bit floating point math.

## First Things First

We only have a few simple suggestions for your first few dates with the SLAM!.

1) Don't rack mount it until you are familiar with the back panel and have experimented a bit with the jacks and switches that you might use later. No problem racking it, but this way is easier at first.

2) Watch those levels. There is a lot of gain and ways to manipulate gain on the SLAM!. We have seen guys set up 30 dB of boost to a line signal, 30 dB of limiting and were not aware of how drastic those settings might be because they were unfamiliar with the box. On he LED meters, one segment = 1 dB (approximately), and if you see the LEDs go half way down, you are hitting 13 dB of limiting which is generally drastic. Most engineers prefer 6 dB or less limiting. You need to use your ears, and your eyes. Common mistake.

a) Unity gain for line inputs is near 12:00 for the INPUT and OUTPUT controls. Begin with the ELOP and FET thresholds fully clockwise (5 o'clock). A good starting point.

b) To set INPUT levels start with the VU on INPUT and the VU attenuator at the "0dB" especially as you become familiar with the SLAM!. You have to be aware that practically all the knobs and switches affect level and gain and that you want to start off on the right foot, so get the INPUT set first. Then set Thresholds and Output level. Most early confusion has been due to level settings.

c) The LED PEAK METER (audio mode) is most useful to view when setting up the limiters and comparing how much louder it can get while hitting the same peak level. Compare your original peak level in Bypass to the level possible with limiting engaged.

3) This is a limiter and limiters generally can create weird distortions especially when the gain reduction is deep and releases are fast. The SLAM! FET limiter has very fast releases so it can be dangerous. The OPTO is easier to use because the attack & release are slower which is why opto's have always been popular. Sometimes we want the ease of opto and the speed of FET, and using the FET gently to 'clean up' the overshoots of the opto is pretty easy too. With the FET limiter alone, some experimentation and critical listening is a must. Different songs and sounds seem to want different settings and one may often be surprised by the optimum setting.

4) Because the SLAM! is old-school analog, the limiters won't have the 'precision' of a digital limiter that can be easily set to hold peaks within 0.1 or 0.2 dB of clipping. If you intend to use it as a brick wall limiter before the A to D converter as a method to be safe/lazy/clever, in an attempt to get hot levels within .2 dB of digital clipping you may be creating the worst case scenario for an analog box. It is difficult to set the SLAM! up to do that. It can be pretty good IF you take the time to carefully set the controls. Foolproof and easy - no, but if you want 'easy', then the safest way is to accept -2 to -5 dB DFS (23+ bits), and use a digital limiter like an L1 or L2 for the last few dBs. The combination provides the best of both worlds. Another approach is to try the "CLIP" setting plus the OPTO which is a bit easier and may or may not be as audible. It might not be worth being obsessed with hitting -.1 dB DFS and focus on the sound instead.

5) Once you have found your favorite back panel settings, feel free to rack mount the SLAM!. Yes, you can leave Phantom on all the time. Old consoles didn't have phantom switches and it was always on - no problem. Most guys stick to one sample rate, 24 bits, and one choice of filters.

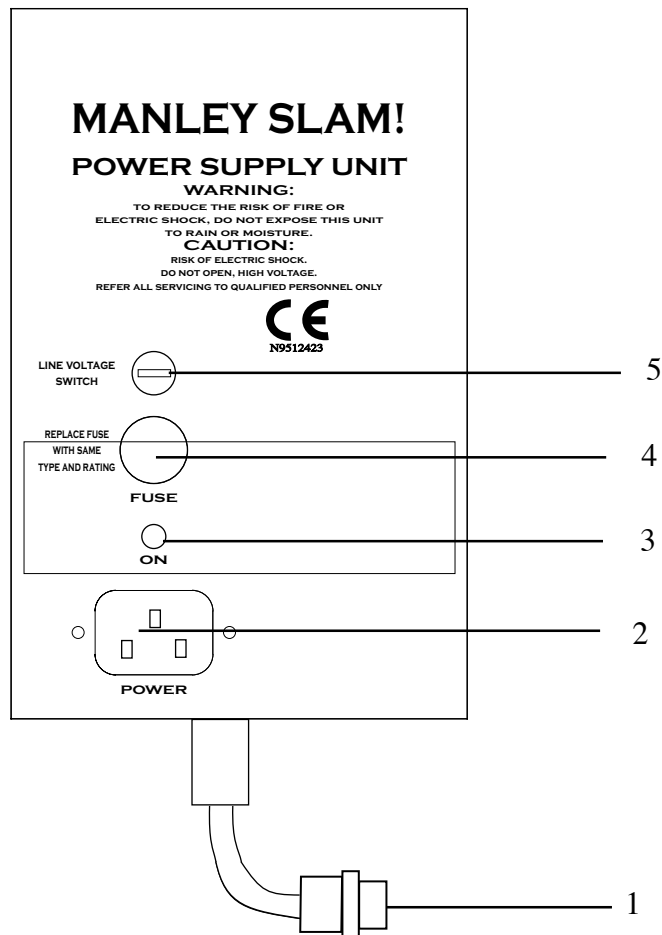

1) **POWER MULTI-PIN:** 16 PIN AMP connector that screws into the matching socket on the back of the SLAM!. This should be connected first. Rotate the whole connector until it mates with the socket, then just a turn or so on the outer ring clockwise will complete the mating. Force will NOT be needed. The cable is 6 feet long and keeping the supply 6-12" away from other gear reduces the possibility of induced hum, though this supply won't radiate much. The supply may get reasonably warm, and this is an intentional trade-off to keep those magnetic fields minimal.

NOTE: The bulk of the power supply will not turn on (including the LED) unless this connector is inserted, because the SLAM! remote controls the power for most of the Power Supply Unit.

2) **IEC POWER SOCKET:** Use the supplied IEC cable to connect the Power Supply Unit to wall current. This supplied cable should be the proper type for your country.

3) **POWER TOGGLE:** "ON" is marked. Note that BOTH this toggle has to be in the 'ON' position and the SLAM! front panel red 'POWER' button has to be pushed to turn on the SLAM!.

4) **FUSE:** The fuse protects you and the SLAM! in case of a catastrophe. Replace only with the same value and type. Failure to do so voids the warrantee. For 117 volts AC mains this fuse is a 2 Amp standard 1/4" SLO-BLO MDL 2. For 220 volts AC mains this fuse is a 1 Amp standard 1/4" SLO-BLO MDL 1. A blown fuse often looks 'blackened'. Several blown fuses indicates a problem needing repair. Both the Supply and SLAM! should be returned to the dealer or Manley Labs for service if the correct value fuses continue to blow.

5) **VOLTAGE CHANGE-OVER SWITCH.** This should be set to the proper voltage for you country by the factory. The switch is marked, and in general a good habit to verify this setting is correct before plugging any new gear in and turning it on. The carton the SLAM! arrives in will also be marked for 117 or 220.

In case you were wondering about the handle, it is to mechanically protect the switches and fuse. The 4 mounting screws allow the supply to be mounted in a rack or screwed down to something.

**THIS PAGE WILL HAVE CONNECTION EXAMPLE DIAGRAMS**

## THE BACK PANEL

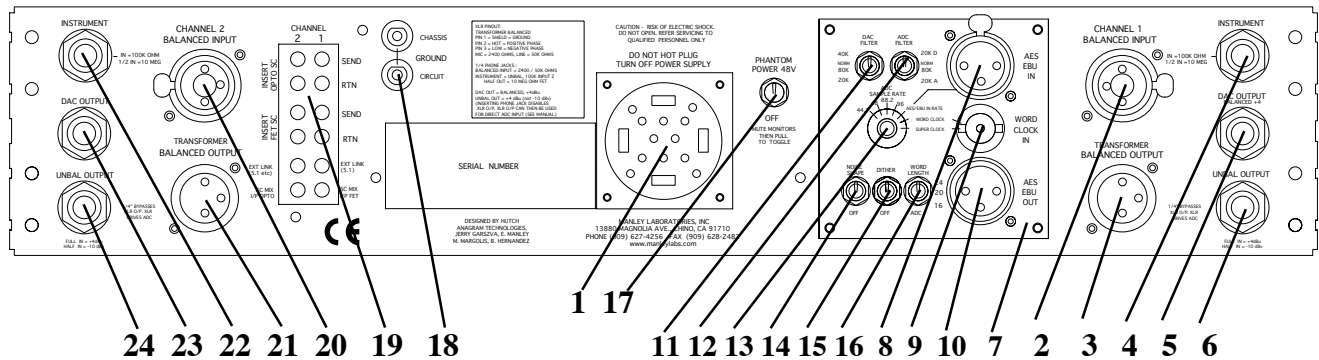

This is just a description of the various jacks and switches on the back. We suggest that you might want to not rack-mount the SLAM! until you've spent some time becoming familiar with the various patching and switches. Sorry, but the back panel is more complex than most gear and there are options galore. That's what happens when you get what everybody asks for.

For simple maps that show a few examples of how to patch the SLAM!, check out Page

1) **POWER CONNECTOR.** First verify the POWER SWITCH on the front panel is off (out) and Outboard Power Supply is off (toggle towards FUSE). The Outboard Power Supply has a captive 6 foot cable, with the mating plug. There is a painted white dot on the plug that should face UP and/or gently rotate it to find the "key" or where it fits. Force is definitely not needed. Rotate the ring on the front of the connector CLOCKWISE about 1 turn, which locks the connector in place.

The SLAM! uses a trickle of power to remote control the power of the main supply. This means the Outboard Power Supply can not be turned on without it being connected to the SLAM!. This is a safety feature. Also, with that exception and the +&-6 volt supply used for tube filaments (heaters) all other pins are protected from passing current or a charge stored on power supply capacitors. In other words, its pretty safe, and that you can't get a shock, and can't power it up hot but still better to have both power switches off to connect this plug.

2) **CHANNEL 1 INPUT.** This is a Neutrik Combo jack that accepts XLRs, 1/4" mono phone plugs, 1/4" balanced phone plugs. This is both the LINE INPUT and the MIC INPUT. Phantom Power (17) is not advised except for some MICs, and in particular FET condensor mics and some rare exceptions that require it. If Phantom is ON, turn it off before patching into this jack (or any other mic patching) or at least turn the monitors, headphones, etc down because there will be a loud speaker killing POP. Contrary to urban myth, it is highly unlikely Phantom Power will damage any mic or cause it to sound different, except during patching. It is a good idea, not to have Phantom on for LINE inputs, as it might be possible to damage something with the 48 volts if you select MIC (which can enable phantom).

3) **CHANNEL 1 OUTPUT.** This is a transformer floating balanced +4 dBu output (Pin 2 hot). It is equally happy feeding balanced or unbalanced inputs but for unbalanced inputs, be sure that the XLR's Pin 3 is grounded or connected to Pin 1 or the shield. There is also a transformerless unbalanced 1/4" phone jack output described below (6).

4) **INSTRUMENT INPUT.** This is a 1/4" mono unbalanced high Z input for guitars, basses, synths, etc. It has about 30 dB more gain than the Combo jack input and uses the mic-pre. The input impedance is 100K suitable for synths and guitar processors/amp simulators but might be a bit dull for some guitars direct. For very high Z (10 meg ohm) physically insert the jack half way. Cool trick, huh? This will sound brighter for many guitars and basses, but should have little or no effect if any electronics are between the guitar and input.

5) **DAC OUTPUT.** (Left) This is a direct balanced +4 dBu output of the DAC if that option is installed. We calibrate the output so that Digital Full Scale = 8.0 volts and that Digital -14 = +4 dBu. Other calibration or reference levels requires a simple internal trimmer tweak.

6) **CHANNEL 1 UNBALANCED OUTPUT.** This jack provides an unbalanced +4 dBu output pre-transformer. It can also provide a semi-pro or consumer -10 dBv with plug inserted half way. Most other Manley gear makes this unbalanced output jack entirely bypass the transformer and thus disables the balanced XLR output. There is an internal jumper to provide this mode, if needed (see page XX). In the SLAM!, the transformer is also used to drive the A to D converter, which we did not want to 'mysteriously lose' when they plugged into the 1/4" output. With the jumper in the alternate position (expert mode), this 1/4" jack can be used as the main output to feed an EQ, and returned to the male 'output' XLR which will feed the A to D directly and passively. We like 'expert mode' but can't ship it that way.

FAQ - Why no -10 input when you provide a -10 output? There is no dedicated -10 dBu input but both the Combo jack (2) and Instrument Input (3) can be used in conjunction with the INPUT knob. Why share the same XLR for both MIC and LINE and no Phantom Switch on the front? It was originally, but we added the HP filter & DAC on that switch, and felt it was 'safer' for your speakers to have the phantom on the back (see item 17).

Why no separate MIC-PRE output? 3 reasons, the mic-pre would require a good line driver (no more space for more tubes), the opto limiter works between both 'sections', and the Combo jack is used by both mic and line. In other words, it required 4 more XLRs and 2 tubes for this box and there is no room. 2 channels & 24 jacks (26) plus 6 switches already, and gotta draw the damn line somewhere. Why use bantam jacks for side-chain inserts? (see 18)

7) **DIGITAL OPTION:** Some SLAM!s will have this converter option and some will not and have just a blank panel fitted. The 'Option' is two parts, and one is this panel with jacks, switches, and its 3 circuit boards. It is intended to be something the average user can install and similar to inserting a PCI card in your computer and attaching a few ribbon cables to it. The second part is a 5"x6" board that contains the converter chips, clocks, PLL, two very high speed SHARC DSPs, and a micro controller. These boards are static sensitive and one must be grounded if handling them. Like, don't be shuffling your feet on the carpet as you go to pick it up.

8) **AES EBU INPUT:** The standard digital input that feeds the D to A converter (DAC). It accepts data or sample rates of 44.1K, 48K, 88.2K and 96K. The sample rate is asynchronously up-converted to 192K and jitter is removed in the process. A dedicated high speed SHARC DSP chip running proprietary code and 40 bit math is used for that. The result is near zero jitter, and audibly less 'time smear'.

Note 1- The DAC outputs are the 1/4" phone jacks (5) and/or can be passed through the tubes, limiters and iron as needed via the SOURCE switch on the front panel.

Note 2- We have used simple XLR to RCA adapters to use SPDIF outputs to feed this jack and it seems to work fine but there are true SPDIF to AES converter/adaptors that would be the officially recommended method.

9) **WORD CLOCK INPUT:** Regular BNC jack that accepts a master word clock or Super Clock. In complex workstation installations often a distributed master word clock is used to guarantee stable and accurate timing across the variety of digital gear in use. With most DACs, this usually helps improve the sound. The most common report is an improvement in imaging. The biggest reason is that it offers a better alternative than AES lines for carrying the clock component, which can be considered an analog signal, and most converters have less than perfect clock recovery or jitter removal circuits (PLLs) (being very polite here). The other reason is that converter chips have what is called 'fixed' coefficient FIR filters that depend on highly accurate clocks and stand crystal oscillator clocks are not usually that accurate. Because the Anagram converter is almost immune to jitter, and uses 'adaptive FIR filters' and not the internal (free) chip filters, the usual audible benefits of the word clock may not apply to this converter. However, probably other components in your system like word clock and this converter retains compatibility (and convenience) by the inclusion of this input.

10) **AES EBU OUTPUT:** This is the A to D converter's (ADC) output. As with the DAC, the actual sample rate is 192K which is down-converted to your choice of data rate from 44.1K to 96K. A second SHARC DSP is used here.

11) **DAC FILTER:** In developing this converter, our research (and Bob Katz) suggested that often the biggest audible differences between converters depended on the designer's choice of filters, so we gave you the choice. The toggle switch provides 3 different filter frequencies, 20K, 40K and 80K passive analog circuits. The 20K and 80K are 3 pole 18dB per octave, and the 40K is 2 pole 12dB per octave, each based on the Manley Massive Passive filters. A good starting point is 80K in a great system and 20K is less harsh / brittle and perhaps warm.

12) **ADC FILTER:** Similar ideas as the DAC filters except the 40K setting has a 1dB bump or boost at 20K for 'air' and a unique feature and is otherwise the steepest of the 3 settings. Note with both 80K filters that because the maximum data rate is 96K and Mr Nyquist's theorem, the maximum true bandwidth is about 45K. If the only concern with filters was the final bandwidth, the 80K would be pointless but because of a variety of factors there does seem to be subtle audible nuances between all 3 filters even at 44.1K data rates (20K BW).

13) **SAMPLE RATE:** The actual sample rate is always 192K and this knob is really a "DATA RATE" control. The seven settings are: 44.1K, 48K, 88.2K, 96K, AES EBU IN RATE (locks to the DAC input AES stream), WORD CLOCK, and SUPER CLOCK, (locks to the clock rate input to the BNC connector). Why no 192K selection? There is no official standard for 192 connections and the default method is 2 XLRs and obviously we didn't have room on the panel, besides we provide the audible benefits of 192K without having to use that high of a data rate. The converter is 'ready' for 192 if it becomes more common and connection to 192 systems becomes more feasible.

Why no WORD CLOCK output? Experts agree that the best A/D clock is its internal crystal, and this ADC is always in that mode even if you lock to the word clock input or AES. As described above, part of the reason better word clock generators sound better than cheaper ones is due to the absolute accuracy (48K=48,000.0000 Hz) and you are better off with a dedicated box with oven controlled crystal accuracy than the built-in clock of this converter, and if desired, the better boxes will lock to the AES output of this converter and allow proper distribution required. In other words, if you are going to do it - do it right, or don't do it. Always listen, and don't blindly trust word clocks.

14) **NOISE SHAPE & 15) DITHER:** The ADC samples at 24 bit resolution, but often we need 16 (or 20) bit data. Simply chopping off the 8 bits results in audible artifacts and a loss of low level resolution. Modern converters add a small (almost inaudible) amount of noise (random numbers from +1 to -1) called dither which effectively smooths the data and removes artifacts (trading audible distortion for a tiny amount of noise). In other words, the signal better approximates the original analog. Noise Shaping is used to describe two different techniques that also help. The first is a method where the dither is pushed to the near ultrasonic and most of the noise energy is focused where we are least likely to hear it so we still retain the benefit of dither but don't hear the noise. The second method uses the difference between the 24 bit data and the 16 bit data (those 8 bits) which can now be considered an error signal, and does the same thing - pushes the energy to the extreme high part of the spectrum, which also seems to increase resolution. Some companies refer to this as 'apparent resolution' and claim, for example, 19 bit resolution on 16 bit data. The biggest difference can be heard on reverb tails and the end of fades and there may be personal preferences involved so it is worth evaluating for yourself. None of this applies with 24 bit word lengths.

16) **WORD LENGTH:** This toggle sets the ADC and AES EBU OUT word length for 24 bit, 20 bit or 16 bit data. Most recording today seems to happen at the highest resolution of 24 bits, but mastering to CD still requires 16 bit data and some MPEG codecs prefer proper 16 bit data rather than 'raw' 24 bit. The NOISE SHAPE and DITHER described above are only active if 20 bit or 16 bit is selected.

**17) PHANTOM POWER SWITCH:** This simply turns on 48 regulated volts of phantom power that 'rides' on Pin 2&3 of the BALANCED XLR INPUT. In this case, it is also only ON when you select one of the 3 Mic modes on the SOURCE switch. However, we do have several warnings:

a) Because you can and will have a typical line input often plugged into that XLR and because you can easily switch to MIC, and because there is a chance some gear is not designed with DC blocking capacitors (or they are rated for less than 48 volts) there is a chance of doing damage to line level gear by 'accident'. We don't know of this ever happening but can imagine that it is possible.

b) In general, patching mics with phantom turned on is a habit to break. Mic signals are typically 1/100th of a volt, and phantom is 48volts so rather huge speaker killing pops are likely - unless monitors, headphones, etc are turned way down or off.

c) For the same reason as above, running mics through patchbays, intermittent cables and corroded XLRs with phantom turned on may be extra noisy and crackley. If you need phantom, you need good solid connections. The only mics that need phantom are most FET condensor mics, and some other internally preamplified mics and a few DI boxes. We don't know of any dynamic mics or tube condensor mics that require phantom.

d) Contrary to urban myth, we also don't know of any mic that can be damaged by phantom, whether it needs it or not, except a few 'modified' vintage ribbon mics that had their protective capacitors removed. Early Neve and Trident consoles applied phantom power to every mic jack and offered no switch to turn it off. It is probably also a myth that some mics sound better with phantom off, but not a myth that bad jacks and cables will sound better with it off. Use phantom power only if its needed.

**18) GROUND TERMINALS:** These provide separate grounds for use in some installations, with special star grounds or other grounding techniques to prevent hum. In most situations the two terminals are simply connected with a wire. The top terminal marked CHASSIS is the AC third pin MAINS ground which also connects to the chassis's, rack rails and can internally connect to XLR pin 1. The bottom terminal marked CIRCUIT is the internal audio ground, which also connects to the 1/4" jacks sleeves.

**19) SIDE-CHAIN INSERTS AND LINKING.** These are all regular Bantam jacks, like are used in most patch-bays. Why these? Again size, space and they offer true, no-BS inserts like a patch-bay does. Most studios have Bantam to XLR adapter cables (we used to chop long patch cables in half and solder on XLRs) and if they don't, they should. All of the outputs are impedance balanced (30 ohms), single ended +4 dBu signals. The inputs are single ended, high Z, with the ring connected to ground through a 30 ohm resistor and should be compatible with most pro gear, balanced or unbalanced.

Some engineers like to patch in an EQ into the side chain of some compressors or limiters which alters how the limiter responds. For example if the EQ is set to boost at 6K (or HP filtered at 3K), the limiter becomes more of a De-esser. Some dynamic controllers seem to be extra sensitive to low frequencies and bass, so we filter out low frequencies to prevent excessive pumping or squashing on bass heavy material. A text-book limiter would not have side-chain inserts because it is supposed to accurately limit true signal peaks. The SLAM!'s Opto Limiter has a switch that provides some side-chain low freq filtering at 100 and 200 Hz. The 200 Hz setting also boosts about 4 dB at 6K, for a bit of gentle de-essing to be the "vocal setting".

Because there are actually 4 limiters in the box, side chain inserts require 8 jacks (sends and returns). The two top jacks are sends for the Opto limiter (L&R) and they are half-normalled to the two returns below them. Some may also use these as alternative outs from the MIC PRE, but the Opto Limiter and, to a lesser degree, the FET Limiter will affect them, but it avoids the final tube stages.

The next 4 jacks are similarly used for the FET Limiter. The Send is an op-amp isolated version of the unbalanced main output. Any plug or patch cord in any of the 'returns' breaks the normal and unless there is a healthy +4 dBu signal inserted there, you won't see any limiting.

The jacks marked EXT LINK (5.1) are just intended for those lucky guys with 3 SLAM!'s who need a way to link 5 or 6 limiters for surround work. Two regular Bantam patch cables are required. These jacks are paralleled, and the rings carries the Opto audio link, the tip carries the FET DC link. The LINK toggle on the front panel must be in the BOTH & EXT position and all controls on all 3 units are used. The Opto Link blends all 6, the FET link uses the moment-to-moment highest signal of the 6 channels.

The bottom two jacks are unused at present, but might be useful for mods and special versions. We had an idea to use them for a 'blend' input because some guys like to use the drum sub-mix to 'push' the 2 buss limiters, but we felt this was a bit excessive and can be done with the above side-chain inserts easily enough.

**20) CHANNEL 2 BALANCED INPUT:** Similar to Channel 1 described by 2) above.

**21) CHANNEL 2 BALANCED OUTPUT:** Similar to Channel 1 described by 3) above.

**22) CHANNEL 2 INSTRUMENT INPUT:** Similar to Channel 1 described by 4) above.

**23) CHANNEL 2 DAC OUTPUT:** Similar to Channel 1 described by 5) above.

**24) CHANNEL 2 UNBALANCED OUTPUT:** Similar to Channel 1 described by 6) above.

## FRONT PANEL

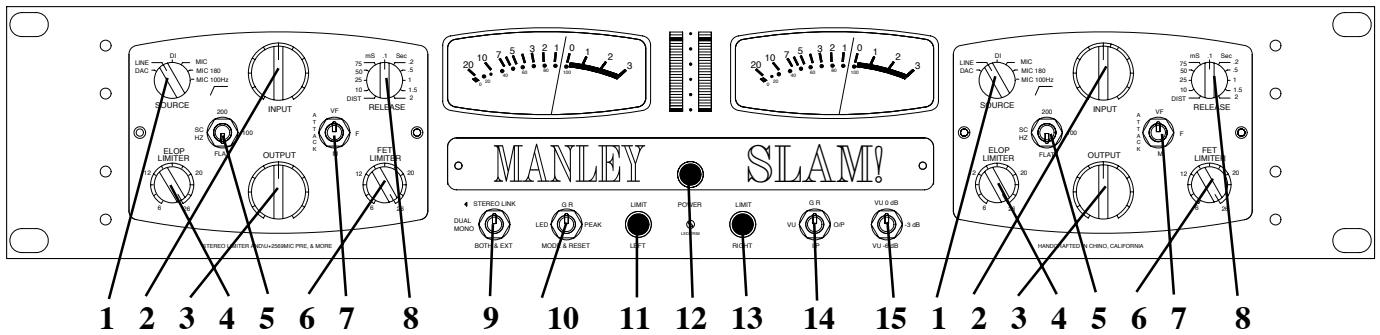

**1) SOURCE:** This is the Input Selector that you use to choose the input to the SLAM!. The choices are DAC (digital to analog converter if this option is installed), LINE, DI, MIC, MIC  $\phi$  (phase reverse), and MIC 100 HZ (high pass filter) which has a little graphic showing the filter. LINE selects the BALANCED LINE INPUT Combo jack (XLR or 1/4") and is intended for +4 dBu signals, but by cranking the INPUT level can be used with -10 dBv signals. DI selects the INSTRUMENT INPUT jack and routes it through the mic preamp for lots of gain if needed. MIC also uses the BALANCED LINE Combo jack and routes it through the mic pre for 60 dB of gain (and another 20 dB by cranking the OUTPUT level). MIC  $\phi$  is the same except opposite and just phase reversed (the proper term is polarity reversed). MIC 100 Hz is normal polarity but the lows below 100 hertz are filtered out which is useful on many vocals and overheads, to remove pops, air conditioning rumble, etc.

**2) INPUT:** This is the first volume control and has about 60 dB of range for MIC and DI, and from -20 to +20 for LINE and DAC. For LINE and DAC, the normal setting will be 12:00, or straight up, but this isn't the rule or an absolute calibration. For MIC or DI, the knob might be anywhere depending on the mic, the loudness of the instrument, the distance, etc., and it might be prudent to turn the knob down to start, rather than starting at 12:00.

**3) OUTPUT:** This is the final volume control and is used to set the output level to tape or disk, and as the 'gain make-up' after the Opto Limiter, if you need to compare 'limit and bypass'. The FET Limiter senses the signal right at the output jack, so it acts as if it is a final limiter after the OUTPUT level. Circuit-wise the FET Limiter is directly after the Opto, and before the OUTPUT level (but doesn't act like it) and before the final tube gain stage/ line driver. The range of this knob is about -20 dB to +20 dB with unity gain near 12:00. Most of the time it will live between 12:00 and 3:00.

**4) OPTO LIMITER:** A simple threshold knob for the OPTO limiter. Fully clockwise (+26) is 'out' and a good place to start. As you turn this knob counter-clockwise, there is more likelihood that limiting will happen. Some dynamics units have the threshold go one way and some the other. On the SLAM!, all of the pots, should make the signal louder when turned clockwise, (except the RELEASE which is a switch).

**5) SC HZ:** Side-Chain Hertz. This is a HP filter in the Opto Limiter side-chain that makes that limiter less sensitive to low frequencies. It does not affect the FET Limiter. The filter helps minimise pumping and strange volume changes. Sometimes kick drums and bass seem to 'trigger' too much limiting. The FLAT setting, bypasses the filter, 100 filters 100 Hz by 6 dB and more for frequencies below that. Similarly 200 filters 200 Hz 6 dB and more below but also boosts about 4 dB at 6 kHz for gentle and subtle de-essing and can be considered a vocal setting. Normally, 2 filters like these require one to change the threshold significantly, but these are compensated to minimise that.

**6) FET LIMITER:** Another simple threshold knob. One can blend any balance of Opto and FET limiters by using the two threshold controls. Each limiter has its own character and advantages, and they complement each other, so that by using both, one can get most of the advantages without the disadvantages. For example, the Opto can limit deeply, smoothly and has a high 'ratio', but is a little slow for drums, while the FET Limiter can be very fast, but not as deep. The Opto has inherent time constants but the FET can be adjusted for attack and release times. What the Opto misses, the FET should catch, depending on how you blend them and the FET ATTACK time.

**7) ATTACK:** This just affects the FET Limiter. With compressors, 'attack knobs' are used to set how fast the compressor responds and pulls down a signal. Traditional limiters don't have this because it compromises the 'concept' of limiting if there is any overshoot. We compromised somewhere between 'text-book limiter' and 'typical compressor', and simulated much of the 'sound' of the attack control while still providing more transient reduction than is apparent. VF is very fast (.1 mS), F is fast (1mS) and M is moderate (10mS). VF is the best if you need to prevent 'overs' and is closest to the traditional or text-book limiter. F and M tend to let more transient through but are also more punchy and may be less detrimental to drums. Expect to adjust the FET LIMIT knob a bit for similar depths of reduction when you change ATTACK (typical). There is another side-chain that grabs much of the peaks, almost inaudibly, but our ears tend to hear the side-chain that has the ATTACK and RELEASE knobs. Use your ears to determine the best setting. Instruments with fast transients like drums show the biggest differences, vocals less so, and soft flute-like sounds may not be affected except for a little threshold difference.

**8) RELEASE:** This only affects the FET Limiter. There are 11 positions numbered from 2 Seconds (slowest), to 10 milli-Seconds (fastest). Slow releases tend to be the least audible and will be cleanest. Medium release times on the SLAM! are pretty fast for a limiter and where the most loudness increase tends to be, but if pushed too far also might be obvious with pumping or a volume rise after the 'crescendo'. This may also be near the edge of when 'modulation' starts to become audible, especially if there is a lot of bass energy in the signal. Achieving maximum loudness cleanly is not automatic and might require a bit of play between threshold(s) release time and attack because it really depends on the music. The SLAM! attempts to minimise all the negatives, pumping, modulation, loss of 'energy' that is typical for a limiter with fast attack and release times because this is where the maximum loudness lives - but - this is dancing on the edge of a dangerous cliff.

The SLAM! release time can be set up for ridiculously fast releases (10 & 25 mS) that pretty much guarantee modulation distortion with lows, which is most often undesirable but can be used as an effect and yet another paint brush. We might caution using ultra-fast release times with bass instruments, but it can be fun on rude drums and blazing solos. There is also a CLIP setting, which introduces a FET clipper that is fairly round like some low feedback tube circuits overdriven and is a bit reminiscent of speaker distortion. We wanted to provide a psycho-acoustic memory of loud, and this is one way. The CLIP is best suited to enhance a moderately distorted guitar, or fatten a synth. It is not intended to replace your Marshall, or amp simulator, but can often be used to take them a bit further.

**9) STEREO LINK:** A 3 position toggle. The center position disables stereo linking and is labelled DUAL MONO. All of Manley's previous limiter/compressors provide a LINK switch and both L&R controls have to be used for proper operation. Meanwhile, most other compressors just use the left side while the right side controls become useless. Enough people requested, for us to include this mode of LINKing. This is the STEREO LINK or up position. Both ways have advantages. The modern 'left-side only' is convenient, easy and can be clever especially on a plug-in. The problem is that almost all implementations mono the L&R, which means sounds that are hard right or left are 6 dB less likely to trigger limiting than sounds down the center, and anything out-of-phase won't be seen by the limiter at all. We think a proper 'mastering compressor' is supposed to react to the peak waveform of both the left and right equally, or stop the same peaks that causes the A/D to clip. This is easy in digital, but in analog it requires the user to use both sides, and that the limiters react equally based on whichever side has the loudest peak. So the SLAM! also has that mode "BOTH & EXT" or the down position. This mode is also used for the back panel linking to other SLAM!'s for surround projects. For recording instruments the STEREO LINK mode is fine but for serious mastering the BOTH & EXT mode is usually best. No LINK of the CLIP functions because why have one side clip the other?

**10) LED (meter):** This switch controls the LED bar graph meter. In the center position is basically an PEAK display of the audio output. The upper position is basically to display GR (Gain Reduction, especially the FET Limiter). The down position is a momentary switch that RESETs the peak hold (clears the dot) and is used to select the LED meter MODE if held down for a few seconds. A full and complete description of the LED Meter is on page 12. Suffice it to say here that it does a lot.

**11) LIMIT LEFT:** Push it in to engage both the OPTO Limiter and the FET Limiter and the OUTPUT level control and it lights up blue. This is not a hard-wire bypass, nor can it be, on a Swiss Army Knife, that has multiple inputs and outputs, mic pre-amps, etc. A hard-wire bypass on a mastering version is a bit more likely.

**12) POWER:** OK, we won't do a 300 word description of a power switch this time. Push it, it lights RED, and turns on the bulk of the Outboard Power Supply, which has been on idle drawing almost zero current. (If it doesn't, remember that there is also a power switch on the power supply that has to be turned on.) The VU meters should light up, and about 30 seconds later the MUTE relay disengages (to prevent tube warm-up thumps) and audio should be available or rising gently. This box has a long warm-up time but should be stable in a minute and very nice in 15 minutes. Power-down mutes immediately. This might be a concern in a live situation, plan accordingly.

If you are not using it for 8 hours, you might as well turn it off to save power bills and tube life. There is a school of thought that suggests that the initial turn-on is the hardest on tubes, and shortens their life and to some degree that is true. From our experience, it all depends on the individual tube and some last 30 years and some 30 seconds. If you are concerned with tube life and down-time, repairs etc, buy a set of extra tubes and save yourself some panic when you least need it. Changing a tube is almost as easy as changing a light bulb and once the top cover is removed should take 20 seconds (compare that to a repair needing the 'ol soldering iron).

**13) LIMIT RIGHT:** Just like 11, but for Channel 2. Push to engage limiting and the OUTPUT level.

**14) VU:** Selects the source for the VU meters. I/P (input) shows the level directly after the INPUT level pot and is a good place to set the MIC-PRE gain or rough out operating levels. O/P (output) shows the output level appearing on the output jacks. GR shows the OPTO Gain Reduction, but not the FET. Most Opto Limiters use a VU to display gain reduction. When the limiters are bypassed the VU drops to below -20 which is not intended to imply extra hard limiting. The Opto can also be displayed on the LED meters, with an expected increase in speed because the Vactrols in the Opto Limiter are faster than VUs.

**15) VU ATTENUATE:** One can also pad the VU's down by 3 or 6 dB which is especially useful if the client is in the room and eyeing the VU needles pegged in the red. Mastering engineers need this because a final mix has a lower ratio of peak to average level, and probably lower again after mastering. The SLAM! will tend to do that too. For individual tracks, we expect the 0 or no pad to be the most common but it depends on the instrument and distorted guitars may few and moderate peaks, but some percussion has huge peaks. We suggest the 3 dB pad for most mastering, and allowing about 3-6 dB below digital full scale on the peak meters. Why? FIR filters usually need 1dB to 2 dB of headroom, MPEG usually requires 4-6 dB, the mastering engineer needs some room to work. The 6 dB VU pad is a hint that maybe this is project is 'hyper-compressed', especially if is still bending far into the red. It is nice for CD playback though.

## METERING

The SLAM! has some very comprehensive metering. If you skip this section, you'll be back here with the yellow highlighter pen, once you start really using the box.

There are both LED bar graphs and standard VU meters, and each can show a variety of information. Before proceeding further, we should mention that any peak meters and VU meters should look different with music and that they are intended for different purposes. VU meters are deliberately slower, and are mostly intended to represent apparent loudness much like the way our ears work. LED peak meters are most often chosen when very fast peak reading signals need to be represented. For "standard" VU meters there is a long list of specs and qualifications, from needle size, color and ballistics to meter size, color and scaling. Most importantly, VUs have been around a long time and most engineers find them easiest to interpret and most valid for analog tape. Because peak meters are fast compared to VUs, transients like drums will look louder than on VUs, and this is a good thing if we are concerned with clipping or digital recording.

The LED bar graphs are multi-color (8), multi-mode (4), and multi-purpose. The meter is controlled by a 3 position toggle switch labeled LED, with MODE & RESET (down), PEAK (middle) and GR (up). During normal operation, the switch will be in the center or up position and will control the display on the meters based on the currently selected mode. The momentary down (spring) position has different functions depending on the current operating mode and how long the switch is held down.

Holding the switch down for more than .5 seconds suspends normal operation and enters the Mode Menu, indicated by a colorful pulsing on the top 2 segments of the right meter. While in this menu, one of 4 Modes described below can be selected. The selected mode is shown by a lit segment surrounded by two others near the bottom of the right meter. You can scroll through the 4 modes by pushing the switch down again quickly (before it returns to 'normal'). Once the desired mode is lit, you 'confirm' the choice by either waiting 2.5 seconds or once again pushing down the switch but longer than .5 seconds. Modes 1 and 2 are the normal display modes and normal operation resumes. Modes 3 and 4 are used to select options.

### Modes

**MODE 1) DUAL DISPLAY:** (shows two things at once)

**Peak Position (center):** Displays audio as a green and amber bar from the bottom up. FET Gain reduction is simultaneously displayed as a red dot from the top down.

**GR Position (up):** Displays FET Gain Reduction as a Green bar from the top down and OPTO Gain reduction as an Orange dot from the top down.

The Peak Hold dot and the third bar color are not available in this 'dual display' mode

In each mode ADC clipping is also displayed. In Mode 1 PEAK the Green segments turn Red. In Mode 1 GR, the Green FET bar turns Red. In Mode 2 you can have the Green turn Red or the top 2 segments turn bright Red depending on where the LED TRIM is set.

**MODE 2) SINGLE DISPLAY:**

**PEAK Position (center):** This is a typical peak meter with a peak hold dot. The bar is divided into 3 colors, Green, Amber & Red.

**GR Position (up):** Displays the sum of FET and OPTO Gain Reduction (or the total limiting) from the top down. Both the limiters are added together which may look a lot more drastic than it sounds and some interpretation is required. It is most useful when minimal limiting is the goal.

**MODE 3) COLOR CHANGE POINTS:**

You can change where the audio peak meters change color from green to amber and from amber to red. This is an unusual feature of this meter and lets you 'match' the SLAM!'s peak meter to the meters on your digital recorder or work-station. The SLAM! meters are analog and your other meters are very likely pure digital so exact segment for segment matching is unlikely. This just gives you a way to set color change points.

Select Mode 3 with the momentary toggle and the display will change so that the left meter is totally lit and the right meter is still in audio peak mode (for reference). Below the POWER button is a small hole and a trim pot lives behind it. A small screwdriver or tweaker is needed to adjust it. If the Mode Switch is in the center position, then you can adjust the point where green changes to amber. **If the Mode switch is in the GR or up position, you can change the amber to red point.**

If you run out of range on the trim, exit Mode 3, tweak the trim to approximately center, then go back to Mode 3 and set the color change point where you want.

If you tweak the orange-red color change point to "over the top of the display" (max), then the ADC clip indication for Mode 2 changes. Instead of the top 2 segments turning bright Red, all the Green segments turn Red when the ADC clips at digital Full Scale.

**MODE 4) PEAK HOLD MENU**

This is just for the peak hold dots in Mode 2. The selection is displayed on the left LEDs.

**a) No peaks held (no dot)** (indicated by the lower of the 3 left segments)

**b) Peaks held for 1 second** (typical generic peak meter) (indicated by the middle of the 3 left segments)

**c) 'Infinite' Hold**, stores the peak until you manually reset by a quick push down and release of the momentary toggle. This mode is handy when the SLAM! is behind you and you need to know after the fact, the loudest transient that went through. Unfortunately, it won't hold a ADC clip indication.

**RESET**

Each time a mode is changed, all settings are saved to non-volatile memory. If you find that you have 'out moded' yourself, or that the meter is looking goofy, the **factory default settings** can be restored as follows. With power off, press and hold the LED Meter switch down, and turn the power on. The left meter will light 2 segments red, the right green, release the switch.

Sometimes the Opto will cause a stuck segment because the opto GR is not slowed down (shared from the VU meter GR mode). Just change to Peak and back will clear the segments, or wait until a the next hot peak clears it for you.

**MODE 1 SELECT MENU DISPLAY**

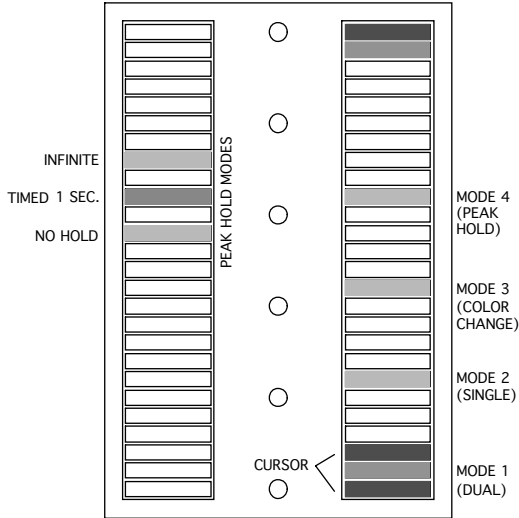

**MODE 1 PEAK Toggle Middle Combination PEAK + FET GR**

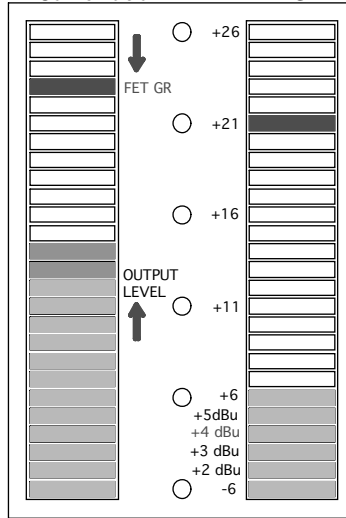

**MODE 1 GR Toggle UP Combination OPTO + FET GR**

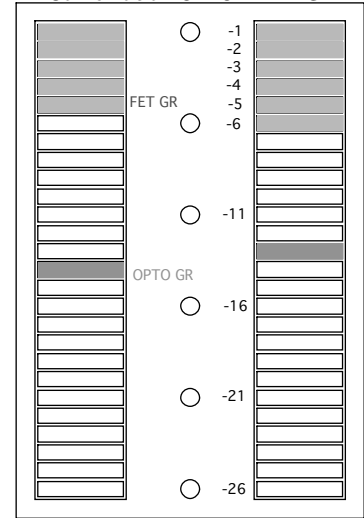

**MODE 2 SELECT MENU DISPLAY**

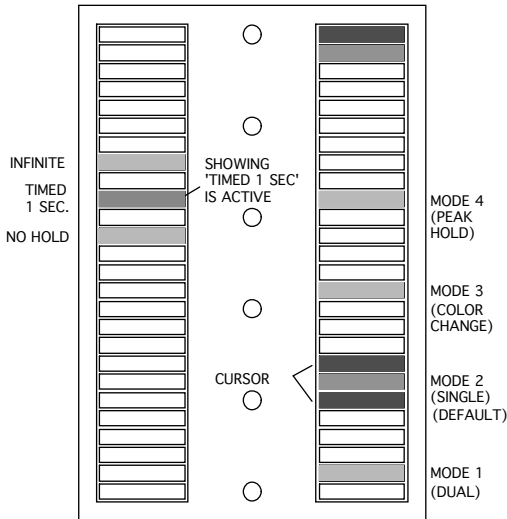

**MODE 2 PEAK PEAK + PEAK HOLD**

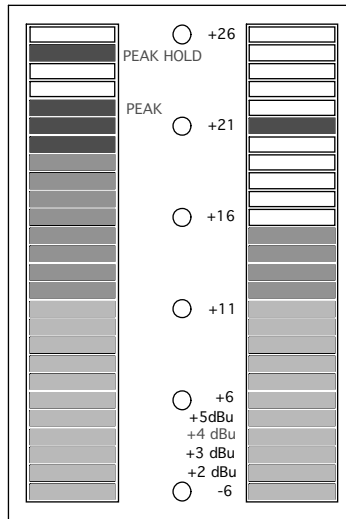

**MODE 2 GR Toggle UP TOTAL FET+OPTO & HOLD**

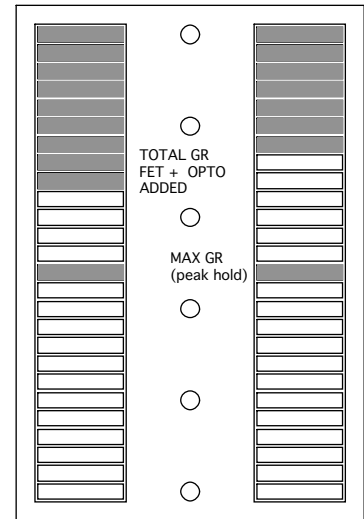

**MODE 3 SELECT MENU DISPLAY**

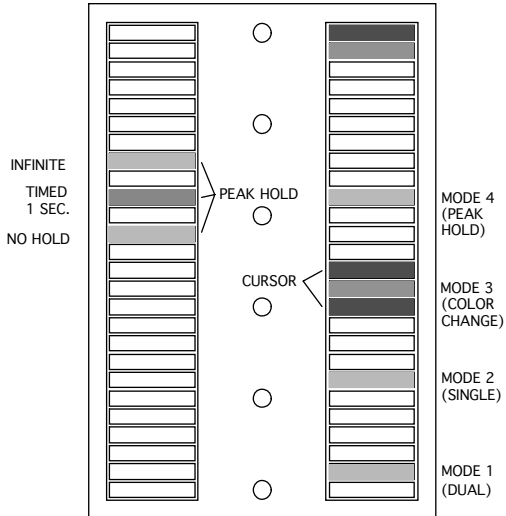

**MODE SELECT 3 COLOR CHANGE SET**

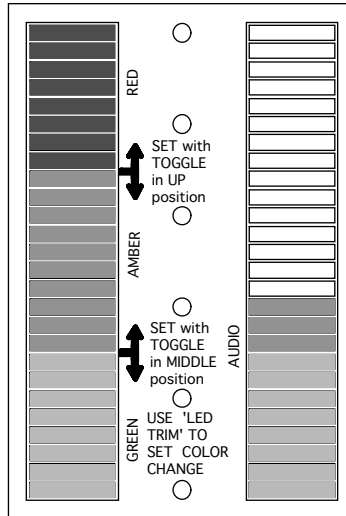

AFTER 2 SECS THESE TOP LEADS ALTERNATE INDICATING OK TO SELECT ANY PEAK HOLD DOT

**MODE 4 SELECT MODE PEAK HOLD TYPE**

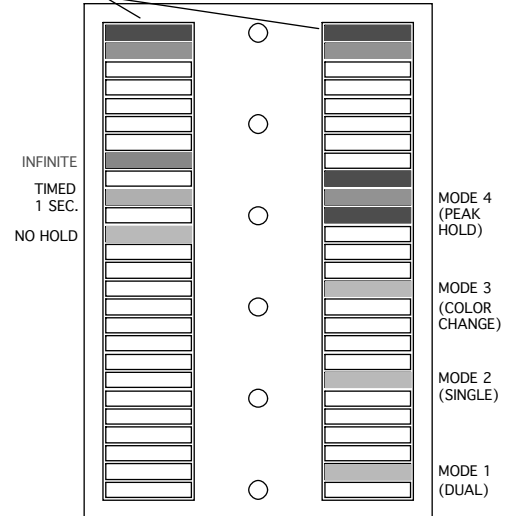

## VU METERS

Two toggles are used for the VU meters. One is used to select whether the VUs display Input Level (after the Input Pot), Output Level, or the OPTO Limiter Gain Reduction. If in BYPASS the OPTO GR the meters drop out rather than sit on zero. A VU meter showing OPTO GR seems to be a bit of a standard and the time constants and ballistics are a good match, even if the VU does not show every drop of gain reduction. The LED meter also can display Opto GR or the total gain reduction.

The second toggle is a pad or attenuator for the VUs in the Input or Output modes and has no effect on GR mode. The 3 position switch gives 0 (no attenuation and calibrated to +4dBu), -3 dB and -6 dB. While it is very unusual to get an attenuator for VU meters on standard rack processors, it is a feature we have been building onto mastering consoles for many years. A regular VU meter would be continually pinned in the red without the attenuator (which may have a disturbing effect on some clients). There are several reasons for this, some pre-dating the trends of heavy squashing. Compare individual acoustic tracks at DFS, to a mix at DFS, and the mix will generally look hotter on the VUs. Mixes tend to have more average energy than individual tracks. Both mixing engineers and mastering engineers often (usually) compress a mix, which also increases the ratio of average to peak somewhat. For example in recording, typical peak to average ratios are 16 to 20 dB, but in mastering 14 dB or less.

The SLAM! is a Swiss Army Knife and is intended to be used for much more than just mixes and mastering. Because it can severely reduce the ratio of average to peak levels, and because most of us now reference levels to digital full scale (a peak reading), it follows that without the attenuator, the poor VUs would be 'in the red' much of their life. We caution that the -6 position can mislead one into a situation where the audio is really too hot, or too squashed. On mastering consoles, the most often used VU pad is -4dB (a hint).

## METERING GENERALLY

The VU meters and the SLAM! peak meters will never agree and maybe the SLAM! peak meters are a little 'off' from the peak meters on an external ADC or DAC. What is going on? Which ones do I trust? How can I calibrate them to look the same?

These questions have been around for as long as there have been meters. VUs should match well with other VUs because there is a comprehensive list of standards and qualifications to meet to be a true VU meter. Part of the specification are 'dynamic characteristics' which describes "The pointer shall reach 99 on the percent scale on 0.3 second, overshoot less than 1.5% (.15dB)". This essentially makes the VU meter act with "approximate RMS" response and our ears have an "approximate RMS response". Ahhhhh loudness.

Peak Meters are much faster and are supposed to catch events less than 0.0001 Sec (compared to the VU's .3 Sec) which means that transients have a much bigger influence on peak meters. One problem is that our eyes won't be able to adequately see a 0.1 mSec flash or even 1 or 10 mSec so the designer has to stretch the duration of the leds or pointer. In a sense, this exaggerates transient contribution, but at least looks good. There can also be a peak hold dot that adds a digital stretch to the duration and allows us the luxury of blinking or looking away once in a while. We have that in mode 2.

In pro audio there are few measurement standards (or even de-facto standards) that exist and peak meter calibrations and digital converter I/O levels are more prime examples. With digital peak meters that are married to digital converters, one at least expects that an 'over' in the A to D over would light the top red LED. Wrong - the better meters use 4 samples over and the best allow that number to be user set. 4 samples over is about the threshold of where we hear a clip. Makes sense to me.

The SLAM! LED meter is not digital, it is an analog meter with a micro-processor. It is not reading the AES-EBU data streams, and *just* measures 6 analog inputs plus 1 signal from the optional A to D (an over that's equivalent to 4 samples at 48K). It can be adjusted for different analog sensitivities with an internal trim pot but this is not guaranteed to 'match' other peak meters nor was it intended to. The SLAM displays approximately 1 dB per segment, except near the bottom which are much bigger steps to show signal present. Other meters may show 2 dB or 1/2 dB steps or be dB scaled on a curve.

Our solution to allow some sort of matching with other peak meters (like the ones on your favorite A to D), is to give you a way to set where the color changes occur. The transition from green to amber is settable, and for mode 2, also the transition from amber to red. This can be done from the front panel without ever removing the unit from the rack or unscrewing the top (mode 3).

In order to provide some useful indication of A to D clip or overs, any green LEDs turn red, which is hard to miss. What is interesting, is that because the meter is looking at analog levels, one can see how many dBs the peak went beyond A to D clipping and this is also a good indication of how audible the clip was.

So to answer the question "Which one should I trust?" the best answer is "all of them with some interpretation and a grain of salt". The VU is best to show apparent volume or apparent GR, the SLAM! peak meters show analog peaks, headroom in the SLAM!, and momentary GR that may or may not be audible, plus shows optional internal A to D clipping. External digital peak meters on the recording device should accurately display available headroom and clipping there. None of them is 100% accurate, nor implicitly perfect, and because each may have different response characteristics, might look different especially after a peak and the rates that dots fall and/or hold. If this is what you would like to calibrate, sorry.

Regarding calibrating exactly how many dBs it takes to hit digital full scale on the A to D, we didn't (and couldn't) put a little trim pot somewhere handy. Why not? The whole front panel is a bunch of level controls or controls that affect level and there ain't no detents. In other words this isn't just a basic A to D that does nothing else. You don't have trim pots, you get a slew of big knobs and 4 limiters to get optimum levels, but not finely calibrated. The other reason is that the A to D front end is a transformer, not a bunch of op-amps.

For the DAC there are trims that can be used to calibrate the back panel 1/4" balanced +4 dBm outputs. We set them so that DFS = 8.0 volts RMS (-16 dB from DFS = 1.27 volts or +4.3 dBm), which is one common standard but there are others (-14 to -20). The DAC signal is reduced 6 dB from the -16 DFS standard if you select the DAC as the SLAM! input. With so many tracks and mixes squashed these days, it allows a better sweet spot for the SLAM!. You can always turn up the INPUT 6dB if you need. With the INPUT at 12:00 a -10 DFS should give 0VU and the 4th LED should light. DFS will pin the VU and the LED will hit about half way up (LED #14).

## LIMITERS

The first compressors we know of used special tubes designed for radio and gain control. These are the "remote cut-off" type like the 6386 as used in the Fairchild 670. Manley has been making the "Variable MU" compressor/limiter for many years based on the same principle.

Opto limiters probably began in the early 60's with the UREI LA2A which used a small electro luminescent panel driven by audio directly from a tube circuit. This panel was in a light shielded box with a photo-resistor so that when the panel lit, the light shone on the photo-resistor which in turn dropped in resistance and shunted audio to ground, and reduced its level. Very simple but effective technique which has stood the test of time. Part of the reason is the simplicity of the 2 knob approach and part is the inherent attack and release times both the electroluminescent panel and photo resistor have and part is the sound of the tube/transformer circuits.

There weren't many companies building pro audio gear in the 60s and 70s, but we had FET limiters, discrete transistor voltage controlled amplifier (VCA) limiters, biased diode limiters and, in general, all had plenty of color and distortion. One of the best known FET based limiters is the UREI 1176 which brought more control to attack and release times and had ratio switches. The first few generations of IC based VCAs were also less than perfect, and VCAs got a bad name but slowly improved over the years. With cheap easy to use op-amps and VCAs, gear prices dropping, music business growing, we began to see more gear but somehow the antique 670s and LA2As and 1176s were still in use and preferred.

In the early 90's a few maverick audio manufacturers including us responded to that knowledge and developed new-old technologies. Manley, for example began the ELOP using a LED/photo resistor component called a Vactrol and combined it with ICs to drive it and tube circuits for the audio. Over the years, that opto circuit was revisited in a discrete transistor Langevin ELOP, variations on the theme used in the VOXBOX and once again here in the SLAM!.

In developing the SLAM!, we began with the idea that probably we could find alternate Vactrols that could be used to give some variety to the opto-limiting. In the end, after trying every one out there, we decided the one we had always used, was our favorite and the others had more drawbacks than advantages. We did improve the drive and metering electronics, and added a HP filter in the side-chain and added the jacks to allow a user to insert their own EQ into the side-chain. In most aspects, the opto-limiter circuit is similar to the one used in our previous Elop's and uses audio to drive the LEDs. This means that we can't possibly adjust the attack and decay characteristics significantly without changing Vactrols. On the other hand, this mode of operation, seems to act more like an RMS responding circuit and reacts to many sounds in a way that we prefer over opto's with the conventional attack, release, etc controls and all the complications that a gain control element with its own timing characteristics adds to that recipe. To make a long story short, we like what happens with that simple old-school approach. The difference in driver circuits plus the side-chain filter does seem to make the opto a lot more useful on mixes and drums than our previous units. We also allow some fast LED metering of the opto in addition to the regular VUs which helps show how fast it tends to react and gives a more complete picture for critical applications.

## "The FET Limiter"

Because we couldn't improve much on our old opto circuit we decided to add a second 'type' of limiter with its own characteristics and its own historical roots. Some early limiters like the 1176 used FETs for the gain reduction element which offered much faster attack times and controllable releases.

The problem with FETs when used as a gain control element is that they can add unpleasant distortion unless the signal is very low (like -30 to -40 dB) and we also wanted a few gain controls which also eat signal unless they are cranked. Throwing op-amps around to get gain where needed is easy, but not our style. Keeping to an all-tube Class-A concept requires different approaches.

We took a novel approach and used a transformer as part of the shunt circuit, which not only reduced the signal to a nice level for the FET but allowed us to use a pair of FETs in counter-phase to reduce distortion. An expensive approach but worth it.

Our main goal of the FET limiter was to achieve the fastest release that we could cleanly. This is the quality that causes the gain to return as fast as possible, which is what gives us our perception of 'loudness'. The goal here was a great 'go-louder' box. Fast attacks, and  $\infty$ :1 brickwall limiting is important to prevent 'overs' but not for increasing the average level. A very fast transient that gets through will clip but as long as the duration is short enough it will not be perceived as distortion. Very fast release times, unfortunately, usually imply modulation distortion where the limiter traces the waveform at low frequencies rather than the volume envelope. This is inevitable, but we made it possible to achieve faster and cleaner releases than usual. It can still get crunchy so be careful.

This FET sidechain uses several techniques to get those fast releases. The usual full-wave rectifier was replaced with a quadrature rectifier that uses 4 phases to determine peaks and allows twice as fast smoothing. Then we combine multiple side-chains and the typical exponential capacitor release was modified for linear decay rates. All of this resulted in faster clean releases, thus more loudness. Still, at the fastest release times it is quite possible to get modulation distortion, which is sometimes a useful color and often a problem with wide spectrum sounds like mixes or instruments with lots of lows. Listen for a growly sounding distortion on faster release times.

The multiple side-chains also gave us the possibility of introducing an attack switch, which is usually not found on a limiter (compressors, yes). The attack switch works on the slowest side-chain, which gives much of the audible familiarity of the control while the other side-chains are still biting the fastest transients. Like most attack controls, as you go from fastest to slowest positions, you tend to lose some threshold or limiting, so adjusting the FET LIMITER threshold will probably be required, conversly more clockwise for VF settings.

A CLIP setting is on the release switch, that introduces a very rounded clipping with a variable threshold. This type of distortion is reminiscent of speaker distortion and tends to be mentally associated with 'loud'. Of course, more conventional clipping is possible and by turning up the INPUT, and turning down the OUTPUT, or if one wants 'drastic' switching to MIC or INSTRUMENT will do that of course. And, no, you won't hurt anything as long as, phantom is off, and you prudently turned the OUTPUT down first. It wasn't designed to simulate a guitar amp but intended to 'assist' an already overdriven tone. Mostly CLIP is used to get a few extra dB of 'angry loud'.

## 'Hyper-Compression'

The word 'Hyper-compression' is a word mastering engineers use and was coined by Lynn Fuston (Mastering Web Board, DSD vs 96/24). For many people it implies the idea of limiting and multi-band limiting and normalizing and squeezing every last drop of apparent volume possible onto a stereo mix but most mastering engineers would prefer not to. It has become almost a contest and everybody wants to be louder than everybody else. Record companies expect it, or ask for it and sometimes demand it. Mastering engineers are expected to do it and are given mixes so brutally squashed that they can't get any louder anywhere without just clipping and distorting.

'Maximizing' level also implies 'minimizing' dynamics and transients. Dynamics and transients are one of the few available 'elements' in sound and music, with the others being pitch, duration and waveform. Very primitive music was just log drums and stretched animal skins, or mostly just transients and dynamics. It's not hard to make 'music' with just transient information, but can you do it with just pitch (like a technician's oscillator), or the one of the other two elements? Dynamics and transients are musical elements and not the enemy.

Maximizing levels very often results in a CD that can exhaust the listener before the first song is over. It can produce an aggressive in-your-face constant barrage that might *not* be appropriate for every project, every song, and every artist. It might be like most effects, best used as an effect and where it is appropriate, sometimes full tilt and sometimes lightly. Super-squashing might also be going out of fashion, and we see a trend where producers are avoiding it.

Maximizing is best done at the mastering stage rather than during mixing, usually. We've heard these stories many times, "The A&R guy (or producer or artist) demanded that the engineer use a certain box to maximize the mix, so he did, but he also supplied the mastering engineer with an alternative version without that box. The mastering engineer did his best with both versions, and everybody preferred the results from the 'raw' tape and hated the maximized mix, and in the end the one from the 'raw' version was loudest anyways". Never heard the opposite story. Why? Mastering engineers generally have the best tools, the most tools, and right tools for the job, and a 'pre-mastered' job often robs his or hers opportunity to apply those tools, and experience, and abilities. If you do use the SLAM! on a mix (before it gets professionally mastered) you should have a version without it and/or a version with light limiting. They also like 24bit masters, and a little headroom (like -3 to -6 dB below digital clipping) and lots of accurate labels/notes. Thank us later.

Maximizing generally does not help the song sound any louder on the radio or TV. Perhaps you know that they are old hands at that game and have compressors, 10 band limiters, 4 band limiters, full range limiters and clippers strapped across the audio chain all the time and have had for 15 years. Everything comes out the same volume - as loud as they can make it. Things can get silly because their boxes were set to work on 'normal' mixes and sometimes they get goofy when given super-squashed songs and songs that have lots of stereo or out-of-phase info. For them, width is bad, mono is good, it transmits further, gets bigger audience share, bigger ad bucks. Car CD players like over-compressed material and many now build a bad compressor into the car stereo, so this is covered too..

So, the SLAM! is another "GO-LOUDER" box, but with a warning label. We are building guns, not pulling triggers. As always, use your ears, judgement, and taste. Be careful with this cannon.

## Hints

Everybody knows that you should make those A to D peak meters go as hot as possible, digital full scale, but NEVER clip. Well, we have two urban myths in that statement. Often enough, the next thing after the A/D (filters, plug-ins, processors & EQs) requires a few dB of headroom and they might have a nasty distortion complete with aliasing if given digital full scale. It is caused by a little ripple in the pass band of the filter that actually can add a little bumps across the spectrum. The 'better' the filter the lower those bumps will be, but they add up. Most filters need between 1 to 3 dB of headroom. Some MPEG encoders need 6 dB. Don't feel compelled to hit DFS if you are working 24 bit and going to master later. Resolution will be fine and a little headroom may be a nice thing 6 dB below DFS. Save almost DFS levels for mastering 16 bit/44.1 CDs that need every bit.

Yes, most early A/Ds sounded horrible when pushed into clipping and clacked, barked and complained loudly. Most modern A/Ds can be pushed a bit 'over' into clipping without obvious distortion and a few (especially older Ultra-Analog based ones) have a pleasant clip. You can certainly get a hotter mix, and more ballz with a little clipping (keyword being little) but our advice is to choose where and how to clip carefully. Usually analog clips better than digital and usually tube units clip better than solid state, but lots of tube boxes don't sound good at all clipping (including some of ours). So, it requires experimentation, (on your time), careful level scaling, and careful listening to highs, lows, peaks and noise. If you do it right, maybe, make a master with level to rival the top mastering engineers, or do it a bit wrong and ruin the project, and have something you regret for a long time. It is not easy or automatic, and boxes that claim to do it usually don't. The SLAM! A/D seems to clip nicely though.

A large part of the trick to getting a hot loud mix is to watch the VUs. The idea is not to see how far the needle can bend to the right, but how still and immobile you can get it and still have it sound like music. Make that needle just sit there while mixing before you limit and then you just need to use a few dB of limiting and loud it will be. This is not so easy to do. Limiting individual tracks and sub-groups makes it easier. Start with the hottest tracks, which are usually vocals, bass and drums. This applies for basic limiters, multi-band limiters and de-essers. Each of these are harder to use effectively on a mix than an individual track or sub-group. On a mix, anything hot can trigger them and they affect everything. If you de-ess a mix, try not to mess up high hats, acoustic guitars & careful EQ settings. De-essing a lead vocal is relatively easy. Limiting a mix will probably seem to affect the drums first, because in a typical mix drums are the source of most of the transient spikes. The initial attack or transient gets pulled down (spikes you probably liked during tracking) but also everything else gets pulled down for that instant. So drums begin to sound more distant and feel pulled back in the mix (and you spent an hour fine tuning that part of the blend), they begin to sound dull (because the transient contains the bulk of their highs), and reverbs and room mics seem to get louder. When limiting hits vocals, some good things and some questionable things can happen. Plosives (Ps, Bs Ds Ks) might get hit and alter carefully sung pronunciations, but sometimes, after EQ, plosives need some taming. Some singers hit high notes a lot harder, and fader-riding, compressors or limiters are needed (hopefully, in that order). In the end, if individual tracks and sub-groups are limited first, then, not only is final limiting and mastering easier, but also it is easier to mix, as well as to create dynamics in the mix. By the way, vintage recordings rarely used a buss compressor - its a fairly new trend. If you do limit the 2 buss, watch out for quiet sections and the drum balance in the mix, and use those ears.

Which brings up the first thing last. The traditional way to have loudness, dynamics, excitement and smoothness all at the same time is with that old tool called 'arranging'. Take another listen to your favorite records and check out how they use many instruments to create loud or a few to create quiet or a relief. Listen to how solos & intro instruments sound great when not covered by everything else. If it happens to be a recording of great musicians playing together, listen to how they are their own automatic level control. This rarely happens with a mostly overdubbed song, but sometimes a great mix simulates it. Dynamics galore, but a constant level, hmmmm.

## OPTIMUM SETTINGS

Sorry, we can't really tell you where to set the knobs for female vocals, a strat, or next year's standard mastering level. It all depends on the track and taste and the sound you are trying to achieve. We can give you a few guidelines and share some experience, if that helps.

Limiting can be more audible or difficult than on a well set up compressor given the same number of dBs of gain reduction. This is because limiting has a higher ratio and typically has faster attacks and releases. Old school engineers advise "to only limit a few dB on occasional peaks", and this is good advice on most limiters. Hopefully, you will be able to limit a little deeper with the SLAM! without the usual problems. A limiter that shows, say, 5 dBs of reduction, can sound louder than a compressor set for 1:1.5 ratio and dropping 10 dB almost steadily. Certainly during quiet passages, the compressor will seem louder, but the limiter can seem louder in the hotter passages when it is just grabbing transient peaks. The compressor might be smoother and more tolerant of settings, but won't offer the protection and 'drive' of a well set up limiter. The compressor's job is to reduce the difference between soft and loud in a smooth even way. The limiter's job is to inaudibly stomp on the hottest transients, and prevent peaks from getting above a set threshold. It's all in the names.

How can you tell when you have it set wrong and set right? There is no 'wrong or right' that applies to every day, but we can suggest the usual things an engineer listens for. You should experiment with some drastic settings when you are alone or can without scaring a client. There are 3 main things and the amount of reduction affects each of them, so it is worth trying some heavy-handed settings to imprint the symptoms to your audio memory.

The first is modulation distortion. When a limiter is set for dangerously fast releases, the bass waveform gets into the sidechain, causing the gain of everything to be changed on a low frequency cycle by cycle basis. The result is a ratty sort of distortion, not really bright and edgy like clipping, but usually not very pretty either, and often not very useful creatively. With the SLAM!'s FET limiter, you can easily set releases that are way too fast and cause modulation if there are any significant lows in the signal. The cure is slower releases, less limiting and/or slower attacks. Settings slower than 100mS are generally pretty safe but always listen.

With the Opto, modulation can happen with about 10 dB or more limiting on bass. You can use less limiting or try the side-chain filter switch. Keep in mind that the side-chain filter will prevent some limiting of loud low notes so there is a some risk of 'overs'. The combination of both the Opto & FET can help share the load for tougher signals like mixes and can be a sweet combination.

The second typical problem setting for limiters and maybe even more for the SLAM! is pumping. The worst case scenario is a mix that has a very hot transient followed by a significantly quieter few seconds. A limiter should grab the peak, shove the gain down sufficiently, then gradually return to normal gain. How gradually depends on where you set the release. If the limiter was set so that it reduced 20 dB, then that quiet passage may rise in level 20 dB over a short time. This can sound pretty wierd depending on that quiet passage. Unfortunately, some of the moderate release times, like between 100mS and 500mS can be most obvious. Unfortunate because, these are typically optimal settings for loudness enhancement. Faster releases might distort and slower might tend to hold the gain down or sit between peaks or beats. We have known a few engineers to change release times on the fly, for transitions between big chorusses and sparse verses that follow, and this can work better than any electronic or algorithmic 'auto' setting.

The third problem is not really so bad unless you are attempting to make the song loud. Releases set too long. When the release is very long, a transient, however brief, triggers gain reduction, and a bar later the gain is beginning to rise back to normal, and boom, another transient reduces the level again. You could have turned down a fader or final gain control and gotten the same effect. The SLAM! isn't immune to this, but the slowest release is moderate at 2 seconds. Some limiters have much longer releases. 8 second releases tend to be safe and almost inaudible, but pulling a fader down a few dB before the song starts is very, very inaudible and does about the same thing. Sometimes the best thing, is to ride the fader, slowly, gently, then add the limiter for what it does best - extremely fast reaction.

**Vocals** can be a prime candidate for limiting. Perhaps the most used limiter ever for pop vocals is the vintage LA2A. The ELOP Limiter in the SLAM! recreates that action, and goes a few steps further with side-chain filters and FET limiter. Start with the ELOP typically on the 100 SC filter (or 200 if esses need a bit of extra taming), get the INPUT & ELOP LIMITER levels optimum, adjust for an optimum level to 'tape'. Then maybe sneak in a bit of FET Limiting, with Attack at VF, RELEASE between 1 sec and 100 mS.

For a **Mix**, we generally lean on the FET Limiter for most of the work. Releases again between 1 sec and .1s are OK, but .1s is verging on dangerous. Attack will be important. VF attacks will sound cleanest but less punchy. Adjust to taste and watch out for loss of drums at VF and distortion at M. Adding some ELOP will be subtle if more than 6 dB of FET limiting is used. We suggest using the 200 SC filter to tame highs and de-ess sometimes.

**Guitars** may like the FET CLIP setting for a bit of extra crunch. **Bass** may require slow releases, and VF attacks for ultra clean sounds, but for extra growl, there are quite a few settings that go there. Faster releases, deeper limiting, and slower attacks each contribute to various distortions, not to mention just overdriving levels. Piano is difficult usually, but try faster attacks, slower releases and not too much limiting.

**Drums** - well, you just gotta play with the SLAM! to find the most appropriate sound. You can certainly tame dynamics, exaggerate room sound, crunch and mangle. Faster release times bring out the room sound and ambiance. It's a bit drastic, but you can use one side of the SLAM! for mic-pre and limiting, go out to an EQ, and return to the other channel for yet more limiting, drive and A/D conversion. You might record that first channel as a minimally processed back-up too. Save something for the mix.

## Limiting and more limiting and more...

The following is a small section of the Orban Optimod-FM, 8400 owner's manual. This is a compressor used by radio stations before they broadcast the music signal. Orban is, by far, the leading company building broadcast limiters in the world. This eloquent piece posted on <rec.audio.pro> by Robert Orban serves as yet another warning for those that intend to use hyper-compression on their mix.

At this writing, there has been a very disturbing trend in CD mastering to apply levels of audio processing to CDs formerly only used by "aggressively-processed" radio stations. These CDs are audibly distorted (sometimes blatantly so) before any further Optimod processing. The result of 8400 processing can be to exaggerate this distortion and make these recordings noticeably unpleasant to listen to over the air.

There is very little that a radio station can do with these CDs other than to use conservative 8400 presets, which will cause loudness loss that may be undesired in competitive markets. There is a myth in the record industry that applying "radio-style" processing to CDs in mastering will cause them to be louder or will reduce the audible effects of on-air processing. In fact, the opposite is true: these CDs will not be louder on air, but they will be audibly distorted and unpleasant to listen to, lacking punch and clarity.

Another unfortunate trend is the tendency to put so much high frequency energy on the CDs that this cannot possibly survive the FM pre-emphasis/de-emphasis process. Although the 8400 loses less high frequency energy than any previous Orban processor (due to improvements in high frequency limiting and clipping technology), it is nevertheless no match for CDs that are mastered so bright that they will curl the vinyl off car dashboards.

We hope that the record industry will come to its senses when it hears the consequences of these practices on the air. Alas, at this writing, they have shown no signs of doing so.

Anyone—please feel free to quote anything I've posted on the board. I am trying to bridge the broadcasting and mastering communities, and the best way is to "get the word out."

This subject has suddenly heated up on the Broadcast.net radio-tech mailing list. Broadcast engineers have become very concerned about the clipped and distorted material that they are being presented with. In fact, one well-respected poster went so far as to propose a minimum peak-to-average ratio spec for material that was to be considered "broadcast quality," and proposed that stations reject any material breaking this spec.

The consensus was that radio stations need "radio-mastered" mixes. These can have all of the EQ and compression applied to the standard release, but need to have the peak limiting and clipping greatly backed off or eliminated. This will retain the flavor added by the mastering, but not the distortion!

In this age of broadband Internet connections, it would be perfectly feasible to service stations with "radio-mastered" singles from a password-protected website. Most stations would prefer uncompressed files to retain quality and prevent any issues with "dueling algorithms," as stations often compress later on in the chain, either when they store the material to hard disk for on-air playback, or in their studio-to-transmitter links (STLs).

<http://www.orban.com/>

We completely agree with Robert's post and the suggestion to create a few masters with lesser amounts of limiting. Hopefully the password protected web-site can become available and producers and/or record companies can post optimized mixes for radio.

Perhaps Robert's post was aimed more at the abuse of multi-band limiters, but the SLAM! can be made to hyper-compress, and/or distort which may cause problems further down the chain than just the basic CD intended for home listening. It is just not that simple.

For example, one might clip a track deliberately for a certain effect or for apparent loudness. If during the song, a section has less highs, a station's multi-band limiter may try to lift the HF bands, exaggerating the HF harmonic distortion and making it more than ugly. In fact, it might make it un-playable by some stations.

What might we suggest? Musicians might try to play at consistent volumes. Mix engineers might limit individual tracks and sub-groups more than the mix. They might also want to rely more on the mastering engineer for final limiting, and their expertise and experience with how product translates to broadcasting. Mastering engineers have to consider the broadcast chains. A&R people have to realize that songs sell records, and a louder CD won't make much difference. In fact, a CD that is too loud, too aggressive, too in-your-face may also be too exhausting to listen to for more than one or two songs - but A&R guys don't read manuals like this.

In more direct practical terms, run the mix 3 times and create 3 versions with different depths of limiting. This gives the mastering engineer more to work with. The mastering engineer can also do the same thing and create 3 masters. Then the only trick is making sure the right parties get the right version, without misdirection.

Another idea mentioned earlier is limiting individual tracks, and sub-groups. One can also create loudness just in how tracks are mixed and EQ'ed. In fact, absolutely great mixes need very little or nothing done in mastering (everybody's elusive goal). The worst mixes need the most processing. Slapping a drastic processor on a bad mix is just that, and doesn't make it a great mix or make real mixing easier or 'mixing' something that everybody can do as long as they have that drastic processor. Just gotta mix well first.

Perhaps the best advice is to do what experienced engineers have done for 50 years with limiters. Use them gently and carefully. A few dB may be better than none, and better than 10 dB of limiting. This, of course, means you have to use your ears and meters and not presets. The idea is not how much limiting you can get away with, but how much and how little is optimum and still sounds good. The usual answer is 2-6 dB on a mix (assuming fast attack time only).

In simple quick comparisons, we generally tend to prefer the choice that is louder and most people can be fooled into thinking X is 'better' than Y even with a fraction of a dB more volume. This is really one place where a bit of extended listening is required to determine which is actually better to listen to for any longer duration. Transients and dynamics can be very nice too.

Maybe you were just thinking, how much (or little, right) should you limit the mix for the mastering engineer. So now you have to consider how much limiting is appropriate for the artist and song, how much is appropriate for the CD and that audience and how much is appropriate for radio, for the label, for vinyl dance tracks..... If only one version is allowed - be careful, avoid regrettable squash.

## Digital Converters

There is a lot of discussion on internet bulletin boards regarding bit depth, sample rates, human hearing, dither, jitter and word clocks. Many people claim to hear a difference between 48K, 96K and 192K and those that perceive those differences seem to generally prefer 192K. Some don't hear the difference. Yours truly has listened to digital for many years, and hosted big A/D and D/A shoot-outs and heard various jitter effects and all the subtle differences between most converters - but - it wasn't until comparing the SLAM!'s DAC to 'conventional' DACs with CDs that a particular problem with those conventional DACs became obvious. The SLAM! DAC was 'faster', and had way better imaging and depth while our conventional DACs sounded slurred, drums were un-focussed, and more effort was required to hear details and mix values. Not quite subtle.

After many hours (weeks) of rigorous calibrated A/B and A/B/X comparisons it became clear that conventional DACs have a ramped-up effect on transients, especially obvious on big bangs out of a black background. In 15 years of listening to digital, I had never noticed this effect, nor had seen any article, heard any discussion, nor had it been suggested to listen for it. With more listening, it became obvious that this effect messes up imaging width and depth & groove or feel. It adds to the harshness of digital and could be a major cause of 'digititus'. Hell, even tapping ones foot to the music, or just enjoying the music was a little more difficult with conventional DACs. We started out calling the effect pre-echo but settled on 'time-smear' as months wore on. There is no official and universally accepted name for this effect. Then came the hard part. What is the cause, who has researched this, why haven't we been told? The cause is half easy and half incredibly difficult. It is easy to demonstrate that the problem is caused by digital brick-wall FIR filters, because one can readily hear the differences as filters are shifted higher and/or made less steep. The difficult and frustrating part is that nobody seems to know why we hear the filters. According to the theories that digital designers live by and our present knowledge of human hearing, we shouldn't be able to hear the difference between a FIR with a 45K corner frequency and one with a 90K corner frequency or one with a more gentle 90K slope - but we do, or at least those who listen do. Pay attention to the leading edge of drums and percussion.

Further discussions with a variety of digital gurus, all seemed to indicate, that they are aware of the 'time-smear' but also have no solid scientific reason for why we hear it. Occasionally somebody with interests in not discussing time-smear will mention "the FIR impulse response ripples are at 22K or higher and we don't hear that". OK, but we DO hear the FIRs all the same. Maybe distortion in tweeters and electronics is a factor and maybe not. Nobody mentioned jitter years ago until help arrived. I don't know why we hear the FIRs either, but because we consider the problem to be very significant for music, we think that you should know it exists and that you should be concerned too. 'Groove' and 'feel' are kind of important in music and time-smear doesn't ever help.

FIR filters have compelling advantages, but perhaps inherent problems that a few expensive converters have minimized. The good news is that a lot of CDs that we blamed mastering or digital for sounding bad, come back to life. Also good news is that time-smear may be reduced to acceptable levels at 192K sample rates (and 48K data rates with SLAM!'s converters). In fact, the SLAM!'s converters have less time smear than other converters running at 192K and are probably the first with this kind of timing performance near this price range.

## The Quantum Converters

When we decided to offer digital converters, the idea was to provide a convenient method to 'insert analog' into a digital studio. Part of the goal was to avoid Phase Lock Loops (PLL's) to recover and clean up the clock signal encoded in AES data streams. Two reasons for this: we feel that most PLLs in use are truly inadequate and it requires a great deal of work, time and intelligence to design a PLL fine enough for 24bit audio. If a converter improves sonically by using a word clock input, this is an indication that the clock recovery is insufficient and that jitter has been audibly attenuated but most likely still a problem. Then we met a new company with a better answer.

The converters in the SLAM! were co-developed by a group of very clever engineers in Switzerland called Anagram Technologies along with bits from us. Anagram mostly design converters for hi-fi companies like Manley, Nagra, Audio Aero, Camelot-Tech and Talk Electronics. **"Anagram Technology DSP filters seem to be the hot new numbers in the digital world"**, (Stereophile, Apr 2002).

Anagram had developed probably the best Asynchronous Sample Rate Converter based on software running in a high speed SHARC DSP chip. The process essentially eliminates jitter and provides the best audible aspects of 192K converters at sensible data rates like 48 or 96K. We can't claim zero jitter, but it's damn close and difficult to measure. The jitter is lower than most converters' internal crystals.

The DSP process borrows concepts from quantum physics. Quantum Theory says we can never know both the mass and energy (speed) of sub-atomic particles at the same time. In digital audio with any amount of assumed jitter, likewise, there is always some uncertainty of the actual sample value because we are unsure of the clock. What makes Anagram's process unique is that both data and clock are treated as a linked pair, and treated with parallel algorithms. Thus the name and a hint of how jitter can be eliminated in software.

In our research and with input from Bob Katz, it became obvious that besides jitter and analog audio implementation, that some of the biggest differences between converters was due to the filters - both the digital and analog varieties. This is why you have 3 choices for both the ADC and DAC. It is unlikely that we can hear beyond 20K or 25K but there do seem to be differences caused by ultra-sonic noise and stray signals that may affect 20-20K audio. Some digital filters and all analog filters, even with 80K 3dB points will create some phase shift within the audio band. This is usually somewhere between subtle and inaudible and may even be desirable. We might prefer the 20K filters when we want some tape-like emulation (especially the DAC) or just 'smooth'. There are also situations when one needs a 20K filter to prevent problems further down the digital chain. Some plug-ins or data-compression algorithms are known to misbehave with ultra-sonic harmonics or noise. 80K is flattest.

The combination of the SLAM! and Quantum was not intended to be the absolute in clinical or sterile conversion. There was some effort to make these into "warm converters" (hot, even). There are no ICs or op-amps from the XLR input to the ADC just class-A low distortion tube circuits. In fact, the input stage of the ADC is totally passive; just a transformer (the warmth), a few inductors and capacitors. With 192K sampling for speedy transients, tubes and iron for the "phat", and limiters for color and ballz, it all should be fun & useful and provide 'personality'. These converters may be even cleaner, crisper and more accurate than most too. You'll just have to compare them to find out.

Here is another great post from Robert Orban dealing with an esoteric audio topic that we also feel is very important, especially in its relevance to brick wall anti-alias filters found in digital converters. This was originally a 2 part post in rec.audio.pro that Robert edited for the 'mastering forum' discussing digital EQ, etc: (9/17/2000)

Regarding the ability to “undo” IIR equalization: Provided that the original IIR EQ is “minimum phase” (it means that all of the z-plane zeros are within the unit circle, and is nearly always true with conventional IIR eq), then a second pass where the z-plane poles and zeros are swapped will completely undo both the amplitude and phase changes caused by the first pass. This will occur with arbitrary accuracy, limited only by the bit depth of the arithmetic used to implement the filters.

The math is very simple:

$$A*(N/D)*(D/N) = A, \text{ where}$$

A is the original signal

(N/D) is the z transform of the first-pass IIR filter, and

(D/N) is the z transform of the second-pass IIR filter, which is the inverse of the first-pass filter.

In fact, it is substantially harder to undo FIR equalization of the linear phase persuasion, because this is non-minimum-phase (there are zeros outside the unit circle in the z-plane), so a stable inverse filter does not exist.

Further, FIR filters “mess up the transient response” too. They just do so in a different way. The tap weights of the FIR define the impulse response of the filter. If you design the filter to be linear phase, then the impulse response is symmetrical around its center, and the part of the impulse response containing significant energy is generally longer than the impulse response of a minimum-phase IIR filter with the same amplitude response as the FIR.

Further, the FIR impulse response will have pre-echo because of its symmetry. The ear has much less ability to do temporal masking of signals occurring before the main energy lobe of a transient than after. So the FIR’s pre-echo is much more likely to be audible on transient material than the impulse response of a minimum-phase IIR filter, where the impulse response occurs after the main energy lobe, and is shorter (not counting the effects of the truncation of the FIR impulse response at its ends).

In fact, the pre-echo of linear-phase FIR filter banks causes notorious problems in the design of perceptual encoders. Advanced coders have to adaptively switch filters depending on the transient content of the program material in order to suppress the audible effects of the pre-echoes. Castanets are a standard means for testing the audibility of this problem.

“Group delay,” unless constant with frequency, HAS NO INTUITIVE PHYSICAL MEANING. (Mathematically, it is the negative of the first derivative of the phase with respect to frequency.)

It certainly does not measure the “time delay” of a given frequency. For example, most minimum-phase highpass filters have negative group delay in certainly frequency ranges. Does this mean that their outputs emerge before their inputs have been applied? Of course not.

In short, it is NOT USEFUL to talk about non-constant group delay as if it had any relationship to time delay through a filter.

Further, there is a lot of careful academic research around that indicates that the magnitude response of a given filter is several orders of magnitude more audible than its group delay response. People keep saying the one equalizer sounds different from another because it has “phase shift.” But just saying it over and over does not make it so.

Further...in the world of linear mathematics, time response and frequency response are uniquely related. If you know the magnitude and phase response of a filter at all frequencies, you can compute the time response. Conversely, if you know the impulse response, you can compute the magnitude and phase response.

This is where you have to be careful. A non-trivial linear-phase filter (like a symmetrical FIR filter) has an impulse response that is SPREAD OUT OVER TIME. The fact that the filter is linear-phase DOES NOT MATTER. It STILL spreads energy out over time. ALL filters “time-smear” their input signals—it is literally how they work. They just do so in different ways.

Minimum-phase filters (like most IIR filters) and linear-phase filters (like symmetrical FIR filters) have impulse responses that are shaped very differently. The peak energy in the impulse response of a minimum-phase filter is asymmetric in time. The majority of the energy occurs right at the attack point, and the energy trails out after that.

In contrast, linear-phase impulse response is symmetrical in time, which means that they have a pre-echo exactly equal to the post-echo.

We can either hand-wave about “phase shift errors,” or we can refer to actual psychoacoustics. In psychoacoustics, there is a phenomenon called “temporal masking,” which means the degree to which the ear is desensitized to energy occurring before and after a “masker,” which is a dominant sound that “drowns out” other quieter sounds.

It just so happens that temporal masking is NOT symmetrical in time. The ear has a much poorer ability to mask sounds occurring before the masker (like the pre-echo of an FIR impulse response) than it is able to mask sounds occurring after the masker. So there is at one argument, based on psychoacoustics, that indicates that a linear-phase filter, by creating pre-echoes in its impulse response, is actually more likely to create audible artifacts than a minimum-phase filter, which does not create pre-echoes.

Further, this is not just theory — it’s a well-known and very serious problem in the design of lossy codecs like the beloved MP3. Good codec designs have to take fairly heroic measures (usually changing the characteristics of their filter banks depending on whether a sound is “impulsive” or not) to suppress the audible effects of the pre-echoes.

My point?

People in pro audio tend to throw around the term “phase shift” without being at all careful. If you hear something different in the sound of two filters, chances are you are hearing differences in the shape of the magnitude response curve, not “phase shift” effects.

And be very careful when assuming that “linear phase” is a Good Thing in filters. It is, in fact, a pretty unnatural sound. Most natural frequency-selective phenomena (like mechanical responses) do not have pre-echoes.

## THE GUTS

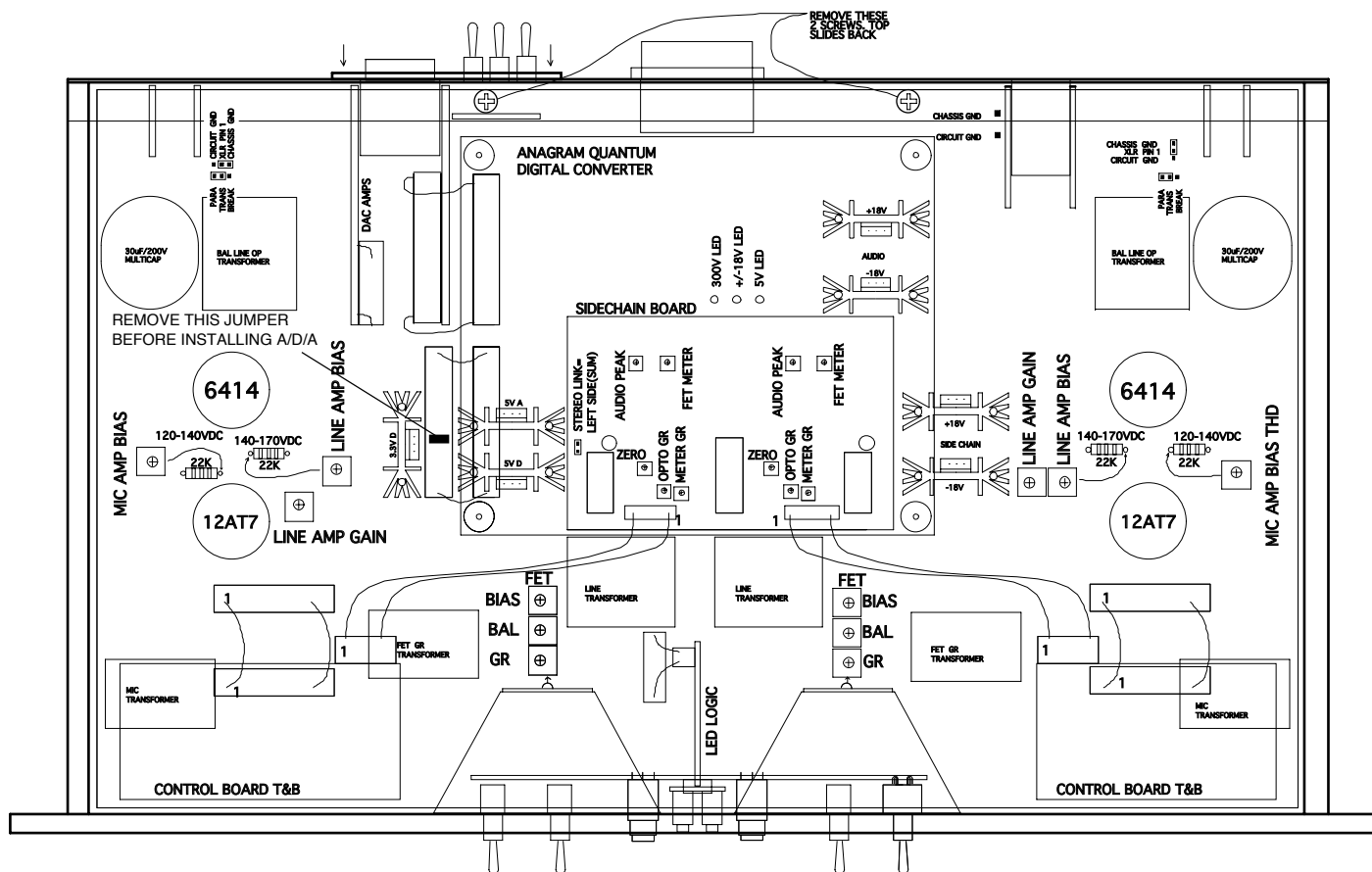

1) **To Open:** Disconnect the AC Power cable, let sit 15 minutes to allow the power supply capacitors to discharge. Remember there are high voltages (350VDC) used in the SLAM! and that the capacitors may continue to hold a charge after AC power and/or power supply connector is removed - Remove the two Philips Machine screws located on the perforated top cover (towards the back). Slide the top cover out towards the back. There are 3 LEDS located towards the back and center. They indicate capacitor charge. If one is lit, wait for full discharge and the LED to completely go out, and then it is safe. **BE CAREFUL!** We suggest using gloves and/or "one hand only" when the top is off when working on tube gear.

2) **Replacing Tubes:** The tubes are marked as to their type 12AT7 (for voltage gain) and 6414 (for line drivers). Another warning: Tubes get HOT. Let them cool before you attempt to touch them. Wiggle the tube back and forth as you pull it up. If you suspect a tube, you can swap it with the other channel. If the problem follows the tube, you were right, it is that tube. If not, try swapping another pair of tubes. It is a good idea to have a few spare tubes for emergencies as this will fix better than 90% of most problems.

3) **Trim Procedures.** This is best done by a trained technician with access to specialized instruments like voltmeters and distortion analysers. Replacing a tube generally does not require a re-calibration. Without a distortion analyser, we suggest 'no touchy' the trims marked THD and BAL. The full factory calibration procedure is on the following page.

4) **Changing JUMPERS:** There are 5 jumpers that allow for a little bit of user modification. The first is in the center and on the left side of the SideChain board. With this jumper IN (factory set), when STEREO LINK is selected, only the left side controls are active and are operating on a summed L&R (mono) signal. With no jumper here, both STEREO LINK and BOTH & EXT use both sets of controls. This mode is a similar to previous Manley compressors, best for mastering, but inconvenient. The second pair of jumpers is for 'Advanced Mode'. The factory sets these to connect PARA and TRANS which allows you to plug into the 1/4" UNBALANCED OUTPUT and NOT disconnect the transformer, A to D converter and XLR output. If the jumper is set to connect BREAK and TRANS, the 1/4" output completely bypasses the transformer, A to D and XLR output. Then the XLR output can be used as an input to the A to D which allows you to insert an EQ (etc) between the 1/4" output and the A to D input. A pair of 1/4" to XLR male and pair of 1/4" to XLR female will usually be the easiest way to patch this. The third pair of jumpers are a grounding option and set whether the XLR outputs are PIN 1 grounded to Circuit Ground or Chassis Ground. These are factory wired for Chassis Ground, so that hum current is dumped to chassis. The XLR inputs are wired for Pin 1 = Circuit Ground because the Phantom Power return is carried on Pin 1 or ground reference.

5) **Replacing Meter Bulbs:** New units like this use very long-life LEDS. For older units lamps are available from Manley (12 volt Festoon) and available from Selco part number 19-29-39/12V. You remove the two small Phillips screws (back, top, center) which allows you pull the white light cover panel away. Gently pry out the old bulb, insert the new one and screw the panel back on. Note that a few of the very first units used 26V lamps and if in doubt, the volts are marked on the bulb.

## INSTALLING THE QUANTUM A/D/A MODULES

- 1) Unplug the power from the SLAM!, wait 10 minutes (to let power supply capacitors discharge)
- 2) Remove the 2 screws from the back of the top perforated cover, slide it back and set it aside.
- 3) Remove the blank back panel, which requires a small Phillips screwdriver to remove the 4 screws.
- 4) Inside the SLAM!, there is an unused 34 pin (2 rows of 17 pins) connector that has a small red jumper across it, 7 pins back from the front. Use needle-nose pliers to pull off that jumper without bending any pins. Set it aside, but don't lose it. It relates to the LED meters and A/D overload.
- 5) Carefully unpack the 2 A/D/A modules, which are static sensitive so you should be grounded and probably have a wire wrapped on your wrist and the wire's other end connected to the SLAM!. You should have 1 medium sized board with two Anagram modules on it, 1 module with the new back panel and 3 boards, with a ribbon cable down the middle, and 2 x 34 way ribbon connectors, and 4 x 4/40 machine screws. Handle them gently.
- 6) The first thing to install is the "back panel module". Orient it so the text on the back panel is right side up and the module should slide reasonably easily through the opening. Next use the needle-nose pliers to connect the small ribbon cable to the pins in the main board - being careful that you have it aligned correctly and aren't about to bend any pins. Push the connector in when it is in place.
- 7) Now you can re-use those 4 screws that you removed in step 3 to attach the A/D/A panel to the SLAM! back panel. It helps to line hole to hole up before putting each screw in.
- 8) Notice there are 2 three pin connectors on one board and there should be two dangling wires with red Molex female connectors already wired in the SLAM!, just waiting to be used. The PURPLE wire (L) goes to the lower 3 pins and the GREY wire (R) goes to the upper 3 pins. Notice that there is a ridge on the Molex connectors that should face the back panel and is the locking mechanism. These two wires carry the balanced DAC lines to the 1/4" balanced DAC OUTPUT JACKS.
- 9) Now you can mount the main board with the two Anagram modules. This board will sit on 4 posts coming up from the SLAM!'s main board so that the board sits roughly center and towards the back of the chassis. Notice there are 2 34 pin connectors along one side - These should be aligned towards Channel 1 or the LEFT side if you are looking at the SLAM! from the front.  
You can use the 4 x 4-40 machine screws to mount the board. Each screw goes thru a corner hole in the A/D/A board and into the posts. Be a bit careful, it is easy to cross-thread the nylon stand-offs on three of the posts, the 4th one is all metal. Locate the black cable (circuit ground cable) That has a washer solder on one end, the washer should be covered with shrink tubing, remove the shrink tubing to expose the washer. The other end of the cable is soldered to the main PCB. This cable might be cable tied to some other wires around the area under the VU meters. (some early units might not have this cable. Unit will work just fine if this wire is not in your unit). Now install this washer between the A/D/A board and the metal post (front & left if you are looking at SLAM! from the front). Now install the 4-40 screw to secure the A/D/A board & and the cable w/washer to the metal post. This wire is a redundant ground connection.
- 10) Now you need to connect the 2 ribbons. The first goes from the SLAM! main board connector (the same one you pulled the red jumper from) and goes to the A/D/A board directly above. Notice that there is a ridge on the center of the ribbon connector and a slot on the board connectors and will physically only plug in one way. The second ribbon goes between the back panel module and the A/D/A board. We suggest folding the excess ribbon so that it sits between the A/D/A and the back panel module board so that it looks neat and doesn't interfere with sliding the top cover back on.
- 11) Time to slide the top back on, screw it down and reconnect power and try out the A/D/A.
- 12) I guess you'll need to connect the AES/EBU cables, set a sample rate, and word length and probably start with the filters set at 80K, but you know how to do all that and the panel is marked.
- 13) If you can, compare these converters with others and with analog tape. Play your reference CDs and especially punchy CDs through this and your previous favorite DAC. Switch between them. The 1/4" DAC outputs are a tiny bit cleaner than going through the tubes and XLR output. Feed a signal to your other A to D converter and the SLAM! simultaneously. Use one DAC and switch the inputs from both A to Ds. Welcome to the world of imaging and transients. Finally try the SLAM! A to D and back through its own D to A and compare that to the original and other converters. We want you to be confident.

## SLAM FACTORY ALIGNMENT PROCEDURE

### Prep:

- 1) +4 dBu (1.23vAC), 1kHz Oscillator fed into XLR LINE INPUTS
- 2) UNBALANCED LINE OUTPUTS feed Level & Distortion Analyzer.
- 3) Select LINE on SOURCE, L&R LIMITERS off, Phantom OFF.
- 4) Set INPUT & OUTPUT LEVELS for 12:00.
- 5) Set ELOP LIMITER & FET LIMITER fully CW.
- 6) Set SC HZ to FLAT, ATTACK to .1 SECOND.
- 7) Set LINK to DUAL MONO (off).
- 8) Set LED to PEAK, VU to I/P, VU to 0dB.

### Power

- 1) POWER UP supply toggle – verify zero AC amps on external Variac current meter.
- 2) POWER UP front panel POWER – spikes and settles to 0.5 amps.  
VU meters lit, POWER button lit RED. 3 internal LEDs lit. LED meter dances.
- 3) After 30 seconds mute relay clicks.
- 4) VU meters should read approximately 0 VU.
- 5) Adjust INPUT for 0 VU, which should be close to 12:00.

### Tube Circuit Trims

- 1) Switch VUs to O/P. Disregard the reading for now.
- 2) Adjust LINE AMP BIAS. The gain should SLOWLY rise and distortion should drop to below .05% (-65) or around -70dB. It helps to set it so the plate volts are about 170vdc. As you adjust the trim watch the distortion and when it ‘nulls’, quickly note the plate volts then it is easier to trim for that voltage than for the distortion ‘null’ because of the slow speed of this trim.  
(FET Drain/Tube Cathode about 10-11vDC and FET Source/2K resistor about 4.5-5vDC, Plate about 160-180vdc, gate about 27mvAC and gain about 34 dB on this stage.)  
Alternatively and assuming no test gear, the highest gain corresponds to the lowest distortion.  
This is a broad peak though and distortion may not be truly minimized but probably OK.
- 3) Adjust LINE AMP GAIN trim for 0VU (+4 dBu) with OUTPUT set to 12:00.
- 4) Verify distortion is nulled (or trim 2 is still at maximum gain)
- 5) Reduce Oscillator by 34dB (24.5mvAC), SOURCE select MIC. VUs should show near zero but won’t necessarily. (no real trim for mic pre gain). Actually the INPUT pot typical +/-20% tolerance is worse than the gain stage errors.
- 6) Adjust MIC AMP BIAS trim for maximum gain & lowest distortion. This is also a slow moving trim and THD&N should drop below .02% or -65db. It helps to set it so the plate volts are about 170vdc. Noise and distortion may look similar in amplitude. VU should read between -2 to +2 (24.5mVAC=0VU). Boosting gain by 25db, should show smooth clipping . 400-80k noise floor should be below -65 dB (-70 typical).
- 7) SOURCE SELECT = Ø. Verify Polarity does reverse (and was correct).
- 8) SOURCE SELECT = 100 HZ. Verify approximately 3dB down at 100 Hz.
- 9) Raise INPUT 16 dB (.154vAC). Change input cable to 1/4” plug and insert it fully into INSTRUMENT. SOURCE SELECT = DI. OP should read about 0VU.
- 10) Pull 1/4” INPUT half way out. Signal should remain near 0VU
- 11) Pull 1/4” OUTPUT half way out. Signal should drop 12 dB (-10dbv)
- 12) SOURCE SELECT = LINE. Raise oscillator by 14dB (back to normal +4 dBu). Check BALANCED output for level and distortion (distortion ‘null’ might drift on a new tube).
- 13) If using AP run a frequency Vs level test to verify flat response.

## **Limiter Trims.**

### **OPTO LIMITER**

+4 dBu (1.23vAC), 1kHz Oscillator fed into XLR LINE INPUTS.

- 1) VU select = GR. Verify reading close to 0 VU.
- 2) L&R LIMIT = ON.
- 3) Verify VU's within 3 dB of zero. Trim ZERO VU GR on Side-chain board so that VU = 0 with no gain reduction.
- 4) VU select = O/P. Set ELOP LIMIT threshold knob to 9:00 O'clock. VU's should show some reduction.
- 5) Adjust OPTO GR trim for 4 dB of limiting.
- 6) VU mode = GR. Adjust opto METER GR trim also for -4 dB displayed on VU's.
- 7) VU mode = O/P Verify operation of STEREO LINK & BOTH&EXT
- 8) Run through SC HZ. Should see more GR at 100 and more at 200.
- 9) Return ELOP LIMIT fully CW (off), Return VU mode = O/P

### **FET LIMITER**

+4 dBu (1.23vAC), 1kHz Oscillator fed into XLR LINE INPUTS

- 1) First do LED METER TRIMS steps 1&2 ONLY !
- 2) Start with FET BIAS, FET BALANCE, FET LIMIT trims in center. (Main Board)
  - RELEASE = .1s
  - ATTACK = VF
  - FET LIMIT fully CW (off)
  - LED = PEAK
  - DUAL MONO. (no link)
- 2) Adjust FET BIAS for 1 dB of reduction.
- 3) Increase oscillator by 6 dB's (Input = 10dBu)
- 4) Adjust FET LIMIT fully CCW.
- 5) Adjust FET BALANCE for maximum gain reduction. Usually trim will sit close to the center position. Trim will show minimum gain reduction in both sides of the trim.
- 6) Return FET LIMIT fully CW (off), Decrease Oscillator by 6 dB's (Output = +4dBu) or (VU = 0)
- 7) Repeat steps 2 to 6
- 8) Adjust FET BIAS for .1 dB ( or just at the threshold when reduction begins ).
- 9) FET LIMIT = 9:00 O'clock. Adjust GR for 4 dB of limiting (Output = 0 dBu )
- 10) LED = GR. Adjust FET METER trim (sidechain board) for 4 Yellow segments lit.
- 11) Increase Oscillator by 6 dB's Verify 12 Yellow segments lit (3rd dot from top).
- 12) Run through RELEASE settings. Should see deeper GR at '2 sec' and less at 10mS in smooth steps with a jump at CLIP. With RELEASE at .1S, run through ATTACK settings, and should see less GR at F and less again at M.
- 13) Decrease Oscillator by 6 dB's (VU = 0), Return FET LIMIT fully CW (off), Return VU = O/P.

### **LED Meter Trims (This is done in MODE 2)**

- 1) With 0VU, adjust AUDIO PEAK trim (sidechain board) for 4 segments lit. Increase oscillator by 6 dB & Be sure L&R are even. Verify 10 segments lit (4th dot from top), adjust AUDIO PEAK trim if needed.
  - 2) Kill oscillator verify no segments lit. Verify -20 dB in lights the first segment.
  - 3) Set LED to GR. With FET LIMIT at 9:00 adjust for 4 Yellow segments lit. Be Sure L&R are even.
  - 4) Use music to verify display is nice, balanced and no segments are dead. Go through Mode 1 Peak and GR, verify in GR both FET and OPTO are displayed. Do the same for Mode 2 Peak and GR.
  - 5) Go to Mode 3, verify LED TRIM (front panel) changes color change point. Leave trim in middle of range. (Factory default 3 Yellow led's lit )
- TO ADJUST :
- A.- Go to mode 3 (left bar lits)
  - B.- Hit reset one more time fast.(left bar flashes) Adjust LED TRIM middle of range.
  - C.- Hit reset one more time fast.(left bar stop flashes) Adjust LED TRIM for three yellow segments lit.
  - D.- Go to mode 2. (Mode 2 Factory default)
- 6) Go to Mode 4, verify Peak, Peak Timed and Peak Hold modes. (Mode 4 Peak Timed Factory default)
  - 7) Power down, hold MODE TOGGLE down, and power up to return to default settings.

Holding the toggle down as you turn power on resets the LED meter to factory defaults.

Holding the toggle down as the meter does its opening dance displays the software version. If the left display shows 3 LEDs and the right shows 2, you have LED Meter Software Version 3.2.

### **Converter Trims**

- 1) Use DAC 1/4" OUTPUT. Feed a CD or AP digital output to the XLR AES INPUT.
- 2) Using a test CD with 1K Digital Full Scale, adjust DAC AMP TRIMS for 4.0 volts RMS on the Tip, and verify Ø 4.0 volts RMS on ring. Total should be 8.0 VRMS.
- 3) SOURCE SELECT = DAC. Verify -20 dB digital signal is approximately 0VU.  
Using music, verify DAC FILTER settings or use AP for frequency response curves.
- 4) SOURCE SELECT = LINE. Connect AES OUTPUT to AP. Verify 0VU = XXX digital. Check WORD, SAMPLE RATE and FILTER settings.

**NOTE. Feel free to calibrate the DAC outputs to match other converters that you use or to your own reference levels. The factory setting might seem "low" if you generally use the 1/4" DAC outputs. It is not easy for us to come up with a generic setting that works universally.**

## TROUBLE SHOOTING

There are a number of possible symptoms of something not quite right, some may be interfacing, others we will touch on as well. If you suspect a problem the following paragraphs should help.

**NO POWER, NO INDICATORS, NADA** - Probably something to do with AC power. Is it plugged in? Check the fuse on the back panel. A blown fuse often looks blackened inside or the little wire inside looks broken or its resistance measures higher than 2 ohms. A very blackened fuse is a big hint that a short occurred. Try replacing the fuse with a good one of the same value and size. If it blows too, then prepare to send the unit back to the dealer or factory for repair. The fuse is a protection device and it should blow if there is a problem. If the unit works with a new fuse, fine, it works. Sometimes fuses just blow for unknown reasons.

**LIGHTS BUT NO SOUND** - First try plugging the in and out cables into each other or some other piece of gear to verify that your wires are OK. If not fix them or replace them. Assuming that cables passed sound - it probably is still a wiring thing. The output XLRs are transformer balanced which require both PIN 2 and PIN 3 to be connected somewhere. When driving an unbalanced input (inserts on some consoles) PIN 3 needs to be grounded or connected to PIN 1. Same with the unbalanced 1/4 inch jacks - if driving a balanced input you can't ignore the negative side. It needs to be connected to the sleeve of the phone plug. Another way to do basically the same thing is join PIN 1 and PIN 3 on the XLR male at the destination. Easiest way - Use the balanced with balanced, unbalanced with unbalanced. That is why the options are there.

**LEVELS SEEM TO BE WRONG, NO BOTTOM** - Several possible scenarios. Manley uses the professional standard of +4 dBm = Zero VU = 1.23 volts AC RMS. A lot of semi-pro gear uses the hi-fi reference of -10 dBm = Zero VU. This is a 12 dB difference that will certainly look goofy and may tend to distort. The SLAM! has plenty of gain available on the INPUT control to accommodate -10 dBv and/or one can use the INSTRUMENT input. For -10dBv outputs, use the 1/4" unbalanced jack with the plug pulled out half way. If the loss looks close to 6 dB and it sounds thin then one half of the signal is lost. The cause is probably wiring again. One of the two signal carrying wires (the third is ground / shield on pin 1) is not happening. Check the cables carefully because occasionally a cable gets modified to work with a certain unit and it seems to work but its wrong in other situations. Sometimes on XLR transformer inputs like this unit one has to connect PIN 3 to PIN 1 and this is easy to do on the XLR cable (it happens with some unbalanced/balanced connections).

**ONE SIDE WORKS FINE BUT THE OTHER SIDE IS DEAD** - Let's assume this is not wiring. We are pretty sure it is the Massivo. If it were solid state you would generally send it back for repair. Being a tube unit, you can probably find the problem and fix it yourself in a few minutes. Not too many years ago, even your parents could "fix" their own stuff by taking a bag of tubes down to the corner and checking the tubes on a tube tester - but these testers are hard to find today. A visual inspection can usually spot a bad tube just as well. Be careful - there are some high voltages inside the chassis and tubes can get pretty warm, but if you can replace a light bulb you should be able to cruise through this. Before you remove a tube, just take a look at them powered up. They should glow a bit and they should be warm. If one is not, you have already found the problem. The tube's filament (heater) is burnt out or broken like a dead light bulb. The other big visual symptom is a tube that has turned milky white - that indicates air has gotten into the tube or we've joked "the vacuum leaked out". Either way replace the tube. Manley can ship you a tested one for a reasonable price. Before you pull a tube, pull the power out, let the unit sit and cool and discharge for a minute or two, then swap the new tube in, then power, then check. Gentle with those tubes, don't bend the pins by trying to insert the tube not quite right. A little rocking of them as you pull them out or put them in helps. If the problem follows the tube you found the problem - a bad tube. No soldering, no meters, one screwdriver - easy. See page 20 for a diagram of tube locations.

**HUM** - Once again - several possibilities - several cures. Most likely it is a ground loop. Ideally each piece of gear should have one ground connection and only one. However, the short list of grounds include the AC mains plug, the chassis bolted to a rack with other gear, each input and each output. The two most common procedures are: try a 3 pin to 2 pin AC adapter (about a dollar at the hardware store). This while legal in many countries can be dangerous- We went one better; Method two - On the back panel loosen the GROUND TERMINALS and slide the small metal ground strap to one side. This is way better than "method one" because it is safer and removes another possible source - the chassis grounding via the rack. Method three - cutting the shield on one end of each cable. This is done by some studios at every female XLR to "break" all ground loops. All the other gear in the rack is "dumping" ground noise onto the ground. Try removing the SLAM! from the rack so that it is not touching any metal. You just may have cured a non-loop hum. Some gear radiates a magnetic field and some gear (especially if it has audio transformers or inductors) might receive that hum. A little distance was all it took. Also the remote power supply box will radiate a 60Hz magnetic field so it should be kept 6"-24" away from gear that may be sensitive.

**IT MAKES NOISES WHEN THE FRONT PANEL IS TAPPED** - An easy one. Some tubes become microphonic over time. That means they start acting like a bad microphone. Vibration has caused the supports for the little parts in the tube to loosen and now the tube is sensitive to vibration. Easy - Replace the tube. Which one? The one that makes the most noise when you tap it. Usually this will be one of the smaller (gain stage) tubes (12AT7A) closest to the front. The SLAM! will have to be on, connected and speakers up but not too loud for the sake of your speakers. With more gain comes more microphonics so be real about your expectations.

**IT GOT HISSY** - Also easy. This is again a common tube symptom. You could swap tubes to find the bad boy, but an educated guess is OK too. Generally the first tube in the path is the one with the most gain and dealing with the softest signals. The usual suspect is the shorter tubes - the 12AT7A voltage amplifiers. You may find that you need to choose the quietest tube out of several of that type - like we do at the factory.

**DISTORTION** - This might be a tube. Swapping is a good way to find out. It may be a wiring thing or mismatch as well. Wiring problems usually accompany the distortion with a major loss of signal. Mismatches are a bit tougher. The SLAM! has a high input impedance and low output impedance that can drive 600 ohm inputs of vintage "style" gear. Best place to start is check your settings and meters. It may not be your first guess.

**GETTING DISTORTION WHEN WE BOOST A LOT**. No doubt. The SLAM! by itself should have enough headroom but it has a lot of available gain. Also the VU attenuator might be at -6dB which hints that the next piece may be getting a very hot signal. You're gonna have to turn something down, whether it is the signal feeding the SLAM!, the INPUT or OUTPUT level or the input level of the next device. You might check that the FET RELEASE isn't set on CLIP too.

**DC OR SOMETHING AT THE OUTPUT THAT IS INAUDIBLE** - The 1/4" unbalanced outputs have a frequency response that goes way down to below 1 Hz. A little very low frequency noise may be seen as speaker movement when monitors are pushed to extreme levels. The XLRs do not exhibit this because the transformers filter below 8 Hz. Also the unbalanced outputs do not like long cheap high capacitance cable. Occasionally a very high frequency oscillation (200 kHz to 400 kHz) may occur in these conditions. Once again use the XLR outputs. Problem solved.

**THE GAIN SEEMS OUT OF CALIBRATION** - Wait a bit and see if it just needs to warm up. There are two trimmers inside for adjusting the gain of the two channels up or down a few dB. More than that and you either have a bad cable or bad tube. In MIC/DI modes there is a huge INPUT Level gain range and most pots do have 20% tolerance of position/value.

Once in a while we get a call from a client with a "digital studio" with confusion about levels. They usually start out by using the digital oscillator from their workstation and finding pegged VU meters the first place they look and they know it can't be the workstation. Even a -6 level from their system pegs the meters. Some of you know already what 's going on. That -6 level is referenced to "digital full scale" and the converter might have 18 or 18.5 or 20 dB of headroom built in. That -6 level on the oscillator is actually a real world analog +12 or +14 and those VU meters don't really go much further than +9 attenuated. There are a few standards and plenty of exceptions. One standard is that normal (non-broadcast) VU meters are calibrated for 0VU = +4 dBm = 1.228 volts into 600 ohms (broadcast is sometimes +8dBm). Another standard is that CDs have a zero VU analog reference that is -14 dB from digital full scale or maximum. This allows sufficient peak headroom for mixed material but would be a bad standard for individual tracks because they would likely distort frequently. This is why digital workstations use higher references like +16 and +20. A VU meter hits red (0VU) at +4 dBm, a digital peak meter hits red at about +18 dBm to +24 dBm. Peak meters and VU meters will almost never agree - they are not supposed to. A peak meter is intended to show the maximum peak that can be recorded to a given medium. VU meters were designed to show how loud we will likely hear a sound and 'help' set record levels to analog tape- they are slower and supposed to approximate RMS levels. By 'help', we mean that they can be only used as a guide combined with experience. Bright percussion may want to be recorded at -10 on a VU for analog tape to be clean but a digital recording using a good peak meter should make the meter read as high as possible without an "over". Here is the second confusion: There aren't many good peak meters. Almost all DATs have strange peak meters that do not agree with another company's DAT. One cannot trust them to truly indicate peaks or overs. Outboard digital peak meters (with switchable peak hold) that indicate overs as 3 or 4 consecutive samples at either Full Scale Digital (DFS) are the best. They won't agree with VU meters or Average meters or BBC Peak Programme (PPM) meters either. Each is a different animal for different uses. When in doubt, use the recorder's meters when recording - they "should" be set up and proper for that medium. Also important - if your external DAC has gain trims, and these trims are "out" it can cause distortion, confusion, and a variety of mis-matches. This is not the type of thing "phone support" is usually good at finding. We have seen guys spend thousands on new gear only to find out a little screwdriver trim would have solved their problems. Our DAC is calibrated for DFS = 8.0 volts RMS which is means a -16 dB DFS signal is about +1/3 dB from 0VU and 0VU is 1.228 volts RMS. SLAM!'s A/D is similarly calibrated so that 0VU should create a -16 DFS digital output. There is no trim for that (strictly passive front end) but there is plenty of gain range on the front panel. To compare & cal this ADC to another, while using SLAM!'s analog outputs to drive the other ADC, tweak the other ADC to match the SLAM!'s ADC using a single meter that shows true digital levels. In normal situations, where the SLAM! just feeds its optional internal converter, this is not an issue. Another point, is that the SLAM! LED PEAK meters are not "true digital" types that watch the ADC. They are hybrid meters with analog inputs and watch the SLAM!'s XLR outputs, and the only thing they see on the ADC is a clip indication of either channel and this causes a total color change.

## MAINS CONNECTIONS

Your SLAM! has been factory set to the correct mains voltage for your country. The voltage setting is marked on the serial badge, located on the rear panel. Check that this complies with your local supply.

Export units for certain markets have a moulded mains plug fitted to comply with local requirements. If your unit does not have a plug fitted the coloured wires should be connected to the appropriate plug terminals in accordance with the following code.

GREEN/YELLOW	EARTH
BLUE	NEUTRAL
BROWN	LIVE

As the colours of the wires in the mains lead may not correspond with the coloured marking identifying the terminals in your plug proceed as follows;

The wire which is coloured GREEN/YELLOW must be connected to the terminal in the plug which is marked by the letter E or by the safety earth symbol or coloured GREEN or GREEN and YELLOW.

The wire which is coloured BLUE must be connected to the terminal in the plug which is marked by the letter N or coloured BLACK.

The wire which is coloured BROWN must be connected to the terminal in the plug which is marked by the letter L or coloured RED.

**DO NOT CONNECT/SWITCH ON THE MAINS SUPPLY UNTIL ALL OTHER CONNECTIONS HAVE BEEN MADE.**

**Note: There is a mains voltage change-over switch that allows the SLAM! to be easily configured for 117V or 220V wall voltage. This switch is on the remote power supply and one needs a flat head screwdriver to change it. This should only be done with the IEC power cable removed. DO NOT set it for the wrong voltage as this could damage the unit. Also the fuse should change when one changes the change-over switch. The SLAM! uses a 2 Amp SLO-BLO fuse for 117 volts and a 1 amp SLO-BLO fuse for 220 volts. A 2 amp fuse for 220 volts prevents the intended protective value of a fuse. A 1 amp fuse for 117 volts will probably blow on power-up.**

## SPECIFICATIONS

### MANLEY SLAM!

#### MIC PRE SECTION:

Frequency Response: +/- 1 dB	10 Hz to 40 kHz
Gain range	+60 to 0 (another +/- 20dB using the OUTPUT Level giving 80 dB total)
Noise Floor (150 ohm source)	-85 dB (A Weight) -X 20 Hz to 20 kHz (ref to +4 dBm)
Equivalent Input Noise	
Input Impedance	approximately 2000 ohms
Maximum Input : 1.5% THD	+20 dBm (typical headroom 20 -20K)
THD & Noise (1kHz, 30mV in, 0VU out)	.1%
Instrument Input (DI) Impedance	100k ohms with jack in all the way or 10 meg with jack 1/2 way in.
(DI) Gain range	+40 to -20

#### LINE & LIMITER SECTION:

Frequency Response	10 Hz to 40 kHz
THD & Noise (1kHz, +4 dBu in, +4 dBu out)	.03% (no limiting)
Maximum output level	+28 dBu (20 to 20K, 100K load), +24 dBm (600 ohm load) +22 dBu (-10 dBv output)
Gain range	-20 to +20 using the OUTPUT Level control
ELOP Threshold	+4 to +30
FET Threshold	+4 to +30
Maximum Limiting	ELOP 25 dB, FET 15 dB, total 40 dB
Ratio (see following page for graph)	ELOP 10:1, FET 5:1
ELOP Attack time (complex)	5 mS
ELOP Release time (complex)	500 mS (fast then slow for final 2 dB)
FET Attack times	VF = .1 mS, F = 3 mS, M = 10 mS
FET Release times	10 mS to 2 sec
VU METER (large Sifam)	3 MODES, Input, Output (A/D input), Gain Reduction (GR) 3 Attenuators, 0 (+4 dBu), -3 (+7dBu) -6 (+10 dBu)
LED METER	26 multi-color LEDs per, multi-function Shows Peak, Peak Hold, Fet GR, Opto GR, and combinations Peak Attack time = .1 mS, Release 250 mS

**OPTIONAL DIGITAL CONVERTER**

2 Module set that can user-fitted into any SLAM! and provide the following:

**Analog to Digital Section:**

Technology	128 x fS oversampling, Proprietary adaptive linear phase FIR (Sharc DSP) using 40 bit FP math. Sample rate always at 192K, "data rate" is user selectable.
Output	AES/EBU 3 pin XLR male plus Word Clock / Super Clock BNC input for clock rate
Sample Rates	44.1K, 48K, 88.2K, 96K, or follows AES in or Word Clock or Super Clock input Actual Sample Rate is ALWAYS 192K and then down-samples to any of the above data rates
Word Length	3 position toggle for 24, 20 or 16 bit data.
Dither & Noise Shaping	Available for 20 or 16 bit output data, Two toggles, Dither is Triangular PDF. Noise shaping is seventh order proprietary.
Anti-Alias Filtering	3 position toggle for 20K passive analog, 40K passive analog, or 20K Digital adaptive FIR using 40 bit Floating Point Sharc DSP. Also uses a 90K FIR in analog modes.
Frequency response	Follows above filters for -3dB points. See curves on page XYZ
Input stage	Entirely passive into the A/D chip, or through tubes, limiters and transformers.
Dynamic range (passive mode)	120 dB
THD + N	96 dB (20-20K), 100 dB A Weighted
Jitter (3% TPDF injected into AES)	no artifacts above -155 dB (essentially unmeasurable)
ASRC distortion & noise	no artifacts above -155 dB (essentially unmeasurable)
Latency	44.1K = 190 samples = 4.3 mS = sound propagation of 4' 9" at sea level 48.0K = 195 samples = 4.1 mS = sound propagation of 4' 6" at sea level 88.2K = 251 samples = 2.8 mS = sound propagation of 3' 1" at sea level 96.0K = 262 samples = 2.7 mS = sound propagation of 3' 0" at sea level

**Digital to Analog Section:**

Technology	128 x fS oversampling, 64 level sigma delta architecture. DAC chip FIR filters bypassed and instead use proprietary adaptive linear phase FIR (Sharc DSP) using 40 bit FP math. Extremely fast transient response and ultra-low jitter optimised design.
Input	AES/EBU 3 pin XLR female plus Word Clock / Super Clock BNC input.
Sample Rates	44.1K, 48K, 88.2K, 96K Actual Sample Rate is ALWAYS 192K and up-samples from any of the above data rates
Word Length	Accepts 16 to 24 bit data.
Anti-Alias Filtering	3 position toggle for 20K passive analog, 40K passive analog, or 80K passive analog
Frequency response	Follows above filters for -3dB points. See curves on page XYZ
Output stage	fully balanced symmetrical low cross-over distortion design capable of driving 50 ohm loads without headroom loss. No capacitors (DC servos). Output is balanced +4 phone jack and/or can be routed through tubes, limiters and transformers.
Dynamic range	115 dB
THD + N	-117 dB (20-20K) @ -60, -104 at DFS
Jitter (3% TPDF injected)	no artifacts above -155 dB (essentially unmeasurable)
ASRC distortion & noise	no artifacts above -155 dB (essentially unmeasurable)
Latency	44.1K = 234 samples = 5.3 mS                      total A to D + D to A = 424 samples = 9.6 mS 48.0K = 237 samples = 4.9 mS                      total A to D + D to A = 432 samples = 9.0 mS 88.2K = 264 samples = 3.0 mS                      total A to D + D to A = 515 samples = 5.8 mS 96.0K = 269 samples = 2.8 mS                      total A to D + D to A = 531 samples = 5.5 mS

**PAGE INTENTIONALLY LEFT BLANK  
WILL DISPLAY 6 CURVES**

**OPTO GR**

**FET GR**

**FREQ RESPONSE OPTO FILTERS**

**FREQ RESPONSE LINE TO LINE**

**FREQ RESPONSE AD FILTERS**

**FREQ RESPONSE DA FILTERS**

## ADDENDUM FOR SLAM! MASTERING VERSION

The mastering version has a number of changes compared to the regular SLAM!

- 1) There are no mic preamps or instrument inputs. Instead the tube sections are paralleled for lower noise and distortion.
- 2) All pots are replaced with rotary switches for detented resettability and easier cal.
- 3) The mastering version has a true hard-wire bypass function, which is not possible on the regular version with mic preamps, etc. What was the Left Bypass, becomes the full Bypass (in stereo and hardwired). No separate L & R bypass buttons.
- 4) The right BYPASS button becomes either the DAC select if the Digital Converter Option is installed – or – Limiter Bypass (tubes & transformers still active)
- 5) There are dedicated unbalanced transformerless inputs on the mastering version. What was the Phantom Power switch on the back now selects XLR or 1/4" inputs.
- 6) The OPTO limiter now has 5 ratios, which may put it into the compressor/ limiter category. The lower ratios may be better suited for complex mixes.
- 7) The FET limiter has 5 modes (these last two features replace the INPUT selector).
- 8) We calibrate/build the digital option for +14dBu =DFS rather than +16 dBu.

About item 6, the OPTO can be selected for 10:1, 5:1, 3:1, 2:1 and a new 'AUTO HF' mode where high frequencies get a higher ratio and low freqs get a low ratio. This mode is the most gentle. As with most compressors one might need to lower the threshold as one lowers the ratio, if keeping a similar depth of gain reduction is wanted. The threshold markings are based on the 10:1 ratio and a setting of +18 is intended to help reduce DFS overs with a converter with 14 dB of headroom over +4 dBm. Many mastering converters are set for 14 dB of headroom and the +18 setting would be a good starting point. Of course being an Opto, it cannot be ultra-fast and some peaks will probably get through and it generally will have the typical (puffy) sound of an opto (because of its inherent time constants). It should be pointed out that much of that character is reduced when used in conjunction with the FET limiter. The FET usually catches some of the overshoots and time/gain behavior of the Vactrol and that can reduce the familiar Opto sonic signature.

The FET limiter has some subtle enhancements, some of which will not be apparent on all sessions. In particular, the LP LIM function will not be obvious unless the input signals are rather hot and more than a few dB of limiting is taking place. LP LIM is meant for those jobs that require more drastic treatments. If those conditions are met, 1) the NORM setting may be verging on 'crunchy' and might seem dulled due to reduced transients, 2) the LP LIM setting can be less crunchy, and seem to have more 'presence' because the FET limiter won't be pulling down as much mids and highs as it will lows where most of the energy is. It may also be difficult to compare NORM and LP LIM because the change involves a 3 or 4 second time constant. At normal levels, the two modes will be similar sounding. LP LIM seems to help in extreme cases where loudness is the prime goal. Use the Bypass button to check how much dynamic presence is added.

The 50% setting mixes some raw input with the post limiter signal, which is often difficult in a mastering environment. Because the FET side-chain senses right off the output XLR, one immediate indication is significantly deeper gain reduction shown on

the LED ladder, but less apparent limiting to our ears. In some ways, it is like reducing the ratio and threshold, maintaining a similar output level. It may sound a bit more open and may be useful where lower level passages need to be raised without killing all transients. Another benefit is that the raw parallel path flows through less circuitry.

The CLIP setting just introduces a soft clip circuit just below +18 dBv or about a dB shy of where a converter set for +14 of headroom might hit DFS clipping. This could allow one more safety valve with a bit of room for the digital filters to behave nicely. One may follow that process with a digital limiter to lift the level a bit closer to DFS if desired.

You may notice that the ATTACK switch simulates some of the audible action we associate with attack controls on compressors but still tends to grab most of the fast peaks. In other words, you get some punch with slower attacks. Like other attack controls you may have to adjust the threshold down at slower settings to maintain some clip protection, but may notice that you don't have to adjust the threshold as much as one might expect with a conventional attack control. This is because there is a very fast limiter still hitting transients that are near our threshold of identifying.

Should also point out that the OPTO side-chain filter has some level compensation built in so that chopping off the lows, doesn't cause a huge change in thresholds. There may be some adjustment required depending on the spectral balance of the music though. With bright mixes the 200 Hz may actually cause deeper limiting, plus there is a 3 dB peak above 4K to help smooth excessive sibilance, though we don't refer to it as a de-esser.

The hard-wire bypass function is not quite as trivial as might be expected. It is a bit more complicated because of 2 input jacks, plus the DAC option and the 2 different outputs, one of which doubles as an input to the A to D option, plus all the metering. Selection of either the XLR balanced (transformer) input or 1/4" unbalanced (op-amp) is done with a "pull to toggle" switch on the back panel. Generally either output can be used and there are internal jumpers that allow the XLR output to be used as an input to the A/D, FET side-chain and OP metering, so that the SLAM! can be used in a wild way with other processors (like a Massive Passive) in a complex chain. Like many of Manley's processors, using the 1/4" unbalanced output bypasses the final transformer and may be a little cleaner or open sounding compared to the transformer output, which may be a little warmer and richer or evocative of some vintage gear. Might be worth checking out each input and output while you learn the unit. Subtle but important differences.

If the converter option is installed, and DAC is selected, it will still be available in bypass. The XLR output will be the same as the dedicated 1/4" DAC output then. The first few units do not pass the DAC to the 1/4" in Bypass (only). It should also be noted that in balanced mode the DAC produces +4 dBm or 0VU @ -14 DFS to the SLAM! circuitry, but in unbalanced mode produces -2 dBm or -6VU @ -14 DFS. This difference might be a flaw or feature, but with the SLAM! being a level changing device, it should not be a problem. The dedicated 1/4" balanced DAC output is -14 DFS = +4 or 0VU. There are a pair of internal trims on the DAC amplifier if a different 'standard' than -14 DFS = 0VU or the consumer DFS = 2 volts RMS unbalanced is desired.

A few points inspired by some of the early comments from SLAM! users, make it into this addendum too.

The SLAM! is designed primarily as an old school text book limiter and as such the Output Level knob is not after the final FET limiter. The idea is to set the peak-stop threshold and adjust the incoming level, which is why the level controls are larger. More fun is to be had adjusting the Input and Output Level controls than the Thresholds, which can often just be thought of as ‘set and forget’ especially if the FET Attack time tends to live in one setting. The Output level is not a ‘gain make-up’ control typical of a compressor but consider it as another Input level before the FET and after the Opto.

Some of the skills or habits we have with soft compressors, might be less useful with a limiter. For example, just setting it by ear, with similar input / output levels and an acceptable number of dBs of gain reduction or approaching it as an effect might not get the best results. The approach of trying to achieve a brick wall level and then tweaking how the unit is driven (those Input and Output knobs) usually seems to work best. Put another way, limiters or limiting is not often a great effect in itself, but the increased volume when it is used reasonably can be. So it is about loudness rather than a cool pumping action, or pleasant warmth. It can do some of that, but was designed to be pretty clean for a tubed unit, and hot aggressive colors can be dialed in with the FET limiter.

The LED Gain reduction display is 1 dB per segment. We have seen numerous people at trade shows dial up 15-30 dB of gain reduction presumably to see a good number of LEDs flashing. It is still a limiter and should be treated with some respect of the damage a powerful limiter in the wrong hands can do. In other words, it can be particularly vicious. The worst-case scenario is bass-heavy mixes, fast attack and releases, and deep limiting, where some GR modulation can happen. Though much has been done to allow those very fast releases, which maximize loudness, it does pay to be aware that distortions and edginess might be a side effect. Sometimes the best answer is exactly what many mastering engineers do daily, which is use 2 or 3 compressor/limiters each doing a few dB rather than one doing 10 dB. The LED meters can be very useful in comparing peak levels, especially when used with the Bypass button. Part of the secret to getting the most out of the SLAM!, is to learn the LED meter modes. Everybody has a favorite display mode, but they all are rather useful and you may find yourself changing modes more than expected. Of course, some rely too much on the meters and forget to listen and assume that particular operating levels are important. There is a healthy range of signal levels that are easily accommodated. We only suggest using less limiting for the first few weeks until you are reasonably familiar with the unit. There is a learning curve and no real tricks or settings that seem to be common. Every mix may be different.

Lastly, it is not in any way like the Variable MU and was never intended to be. Each has its own purpose and special ‘unique talent’. The SLAM! may be easier to describe as a damn-fast transient killing secret weapon, or a tubed, analog L-2 with amazing converters, or maybe just a serious “go-louder box” with huge cajones. Enjoy!

## WARRANTY

All Manley Laboratories equipment is covered by a limited warranty against defects in materials and workmanship for a period of 90 days from date of purchase to the original purchaser only. A further optional limited 5 year transferrable warranty is available upon proper registration of ownership within 30 days of date of first purchase.

Proper registration is made by filling out and returning to the factory the warranty card attached to this general warranty statement, along with a copy of the original sales receipt as proof of the original date of purchase, or registration can be made online in the Tech Support section of [www.manleylabs.com](http://www.manleylabs.com).

This warranty is provided by the dealer where the unit was purchased, and by Manley Laboratories, Inc. Under the terms of the warranty defective parts will be repaired or replaced without charge, excepting the cost of tubes. Vacuum tubes and meter or badge lamps are warranted for six months provided the warranty registration is completed as outlined above.

If a Manley Laboratories product fails to meet the above warranty, then the purchaser's sole remedy shall be to first obtain a Repair Authorisation from Manley Laboratories and return the product to Manley Laboratories, where the defect will be repaired without charge for parts and labour. All returns to the factory must be in the original packing, accompanied by the Repair Authorisation, and must be shipped to Manley Laboratories via insured freight at the customer's own expense. Factory original packaging can be ordered from Manley Labs. Customer will be charged for new factory original packaging if customer fails to ship product to Manley Labs in the original factory packaging. After repair, the product will then be returned to customer via prepaid, insured freight, method and carrier to be determined solely by Manley Laboratories. Manley Laboratories will not pay for express or overnight freight service nor will Manley Laboratories pay for shipments to locations outside the USA. Charges for unauthorized service and transportation costs are not reimbursable under this warranty, and all warranties, express or implied, become null and void where the product has been damaged by misuse, accident, neglect, modification, tampering or unauthorized alteration by anyone other than Manley Laboratories.

The warrantor assumes no liability for property damage or any other incidental or consequential damage whatsoever which may result from failure of this product. Any and all warranties of merchantability and fitness implied by law are limited to the duration of the expressed warranty. All warranties apply only to Manley Laboratories products purchased and used in the USA. All warranties apply only to Manley Laboratories products originally purchased from an authorised Manley dealer. Warranties for Manley Laboratories products purchased outside the USA will be covered by the Manley Importer for that specific country or region. "Grey Market" purchases are not covered by any warranty. In the case that a Manley Laboratories product must be returned to the factory from outside the USA, customer shall adhere to specific shipping, customs, and commercial invoicing instructions given with the Return Authorisation as Manley Laboratories will not be responsible for transportation costs or customs fees related to any importation or re-exportation charges whatsoever.

Some states do not allow limitations on how long an implied warranty lasts, so the above limitations may not apply to you. Some states do not allow the exclusion or limitation of incidental or consequential damages, so the above exclusion may not apply to you. This warranty gives you specific legal rights and you may also have other rights which vary from state to state.

For Tech Support and Repair Authorisation, please contact:

**MANLEY LABORATORIES, INC.**  
**13880 MAGNOLIA AVE.**  
**CHINO, CA. 91710 USA**  
**TEL: (909) 627-4256**  
**FAX: (909) 628-2482**  
email: [service@manleylabs.com](mailto:service@manleylabs.com)

# WARRANTY REGISTRATION

We ask, grovel and beg that you please fill out this registration form and send the bottom half to:

MANLEY LABORATORIES  
REGISTRATION DEPARTMENT  
13880 MAGNOLIA AVE.

CHINO CA, 91710 USA

**Or** you may FAX this form in to: +1 (909) 628-2482 **or** you may fill in the online warranty registration form found in the Tech Support section of our website [www.manleylabs.com](http://www.manleylabs.com) **or** you can be really diligent and register your warranty three times to see if we get confused!

Registration entitles you to product support, full warranty benefits, and notice of product enhancements and upgrades, even though it doesn't necessarily mean that you will get them (Just kidding!) You **MUST** complete and return the following to validate your warranty and registration. Thank you again for choosing Manley gear and reading all the way through The Owner's Manual. (We really mean that sincerely, the bit about thanking you for choosing our gear. THANK YOU!!!)

MODEL \_\_\_\_\_ SERIAL # \_\_\_\_\_

PURCHASE DATE \_\_\_\_\_ SUPPLIER \_\_\_\_\_

-----  
*PLEASE DETACH THIS PORTION AND SEND IT TO MANLEY LABORATORIES*

MODEL \_\_\_\_\_ SERIAL # \_\_\_\_\_

PURCHASE DATE \_\_\_\_\_ SUPPLIER \_\_\_\_\_

NAME OF OWNER \_\_\_\_\_

ADDRESS \_\_\_\_\_

CITY, STATE, ZIP \_\_\_\_\_

EMAIL: \_\_\_\_\_

TELEPHONE NUMBER \_\_\_\_\_

COMMENTS OR SUGGESTIONS? \_\_\_\_\_

\_\_\_\_\_

## **A FEW EXAMPLE SETTINGS**

**(PEOPLE, PLEASE SEND IN A FEW OF YOUR FILLED IN TEMPLATES, AND GET YOUR NAME OR INTERNET NAME IN A MANLEY MANUAL. THIS PAGE IS ONLY BLANK BECAUSE NOBODY HAS SENT IN A FEW REAL WORLD SETTINGS YET.)**

TEMPLATES FOR STORING MANLEY MASTERING SLAM! SETTINGS

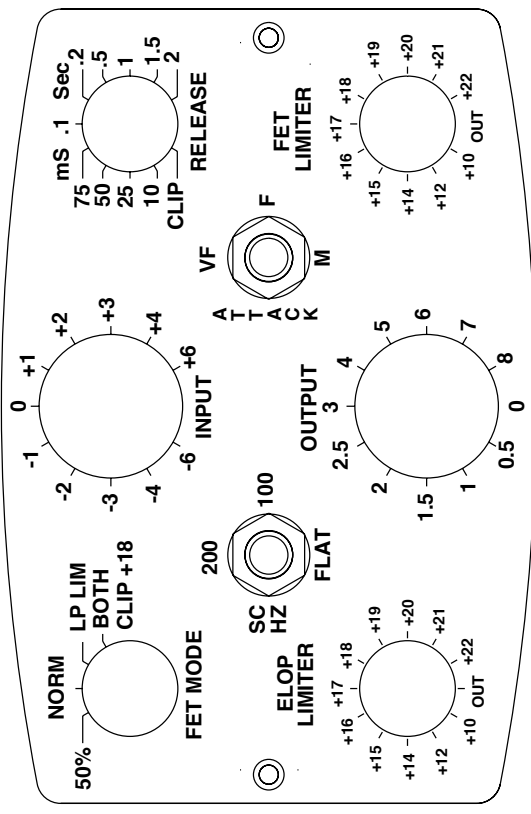
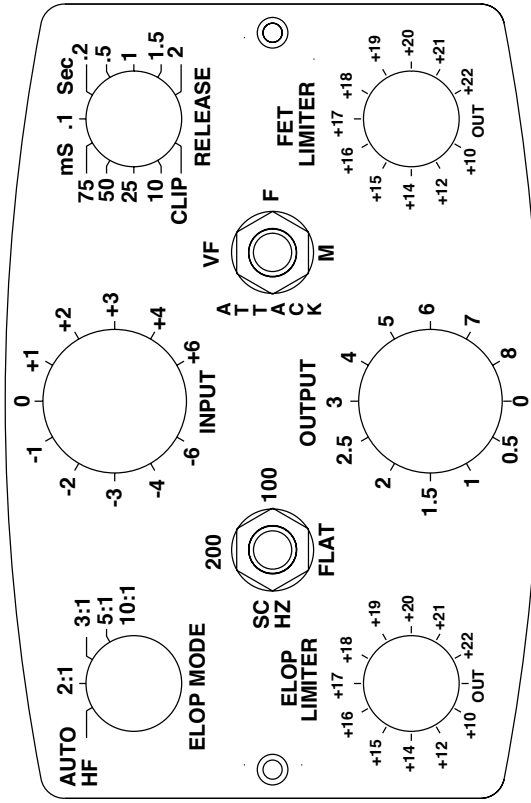

PATCHING

- Limit:  IN  OUT
- Link:  Stereo Link  LED METER MODE.....
- Dual Mono  LED METER DEFLECTION .....
- Both & Ext
- Input:  Balanced XLR  VU METER MODE.....
- UNBalanced 1/4"  VU METER ATTEN .....
- DAC  VU METER DEFLECTION .....
- ADC via XLR OP
- Output:  Balanced XLR
- UNbalanced 1/4"
- DAC Output
- Side Chain ELOP.....
- Side Chain FET.....
- ADC/DAC
- DAC Filter:  40K  80K/norm  20K
- ADC Filter:  40K  80K/norm  20K
- ADC Sample Rate:  44.1  48K
- 88.2  96K
- AES  Word Clock
- Super Clock
- ADC Word Length:  24  20  16
- Dither:  ON
- Noise Shape:  ON
- LINK 1 .....
- LINK 2 .....
- Side Chain ELOP.....
- Side Chain FET.....

PROJECT	ENGINEER	CHANNEL 1 TRACK
SONG	DATE	CHANNEL 2 TRACK
NOTES		

# TEMPLATES FOR STORING MANLEY SLAM! SETTINGS

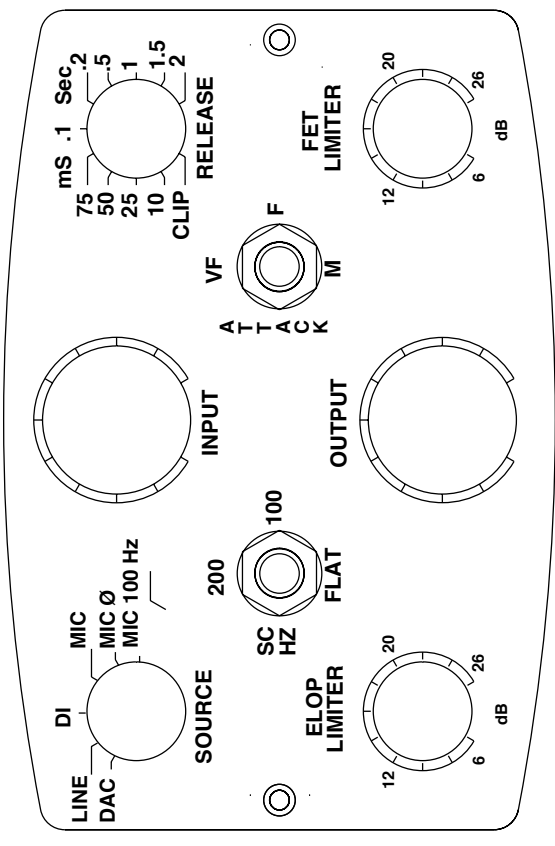
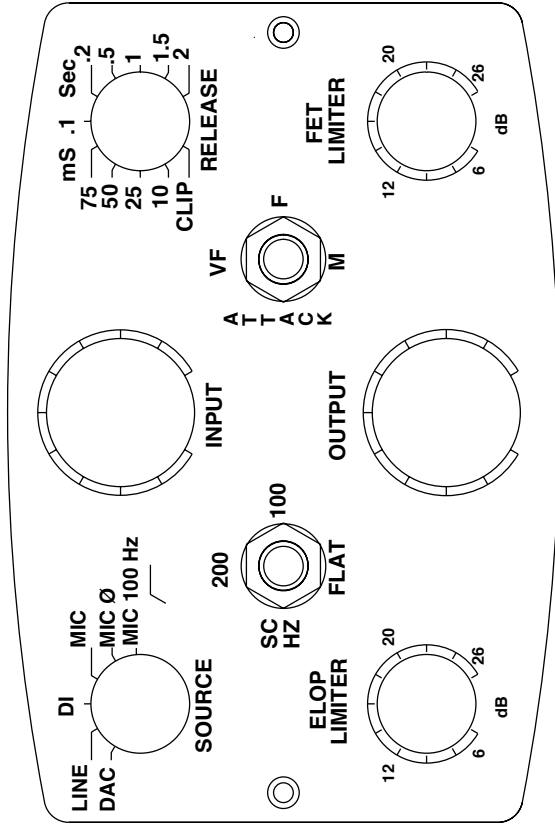

## Channel 1

- Limit:  IN  OUT
- Input:  Balanced XLR  Balanced 1/4"  Instrument  Instrument half out  DAC  ADC via XLR OP
- Output:  Balanced XLR  Unbalanced 1/4"  Unbalanced 1/4" half out  DAC Output
- Side Chain ELOP .....
- Side Chain FET .....

## Channel 1

- Limit:  IN  OUT
- Input:  Balanced XLR  Balanced 1/4"  Instrument  Instrument half out  DAC  ADC via XLR OP
- Output:  Balanced XLR  Unbalanced 1/4"  Unbalanced 1/4" half out  DAC Output
- Side Chain ELOP .....
- Side Chain FET .....

- Link:  Stereo Link  Dual Mono  Both & Ext
- ADC/DAC:  40K  80K/norm  20K  40K  80K/norm  20K  44.1  48K  88.2  96K
- DAC Filter:  40K  80K/norm  20K
- ADC Filter:  40K  80K/norm  20K
- ADC Sample Rate:  44.1  48K  88.2  96K
- ADC Word Length:  24  20  16
- Dither:  ON  OFF
- Noise Shape:  ON  OFF

PROJECT	ENGINEER	CHANNEL 1 TRACK
SONG	DATE	CHANNEL 2 TRACK
NOTES		